

 **RenewAire**<sup>TM</sup>  
*Energy Recovery Ventilation*  
*Think Greener. Breathe Better.*

COMMERCIAL PRODUCT CATALOG

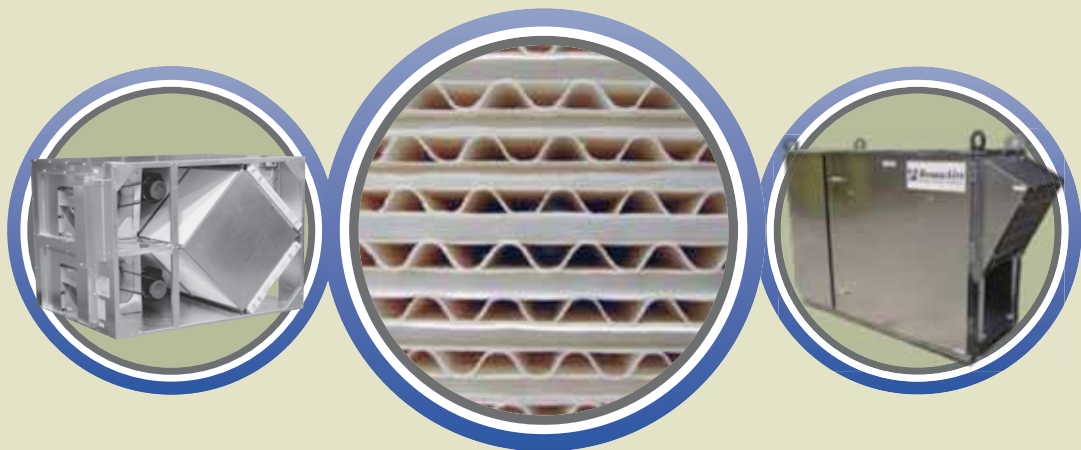

[www.RenewAire.com](http://www.RenewAire.com) • (800) 627-4499 • Fax: (608) 221-2824  
4510 Helgesen Drive • Madison, Wisconsin 53718 USA

In CANADA

[www.MitsubishiElectric.ca](http://www.MitsubishiElectric.ca) • (905) 475-8989 • Fax: (905) 475-5231

In MEXICO, CENTRAL and SOUTH AMERICA and the CARIBBEAN

[www.Soler-Palau.com.mx](http://www.Soler-Palau.com.mx) • 52 (222) 2 233 911 • Fax: 52 (222) 2 233 914

# ENERGY RECOVERY VENTILATION: THE PROVEN ADVANTAGES OF HEAT AND HUMIDITY TRANSFER

## *Improves Indoor Air Quality*

By providing simultaneous exhaust and fresh air supply, RenewAire reduces the concentration of harmful pollutants in indoor air - an absolute must in schools, offices and smoking environments.

## *Meets Ventilation Codes for Air Exchange*

Provides ample ventilation to meet ASHRAE 62 and the International Mechanical Code that now requires two to three more air exchanges than in the past.

## *Controls Excess Moisture*

Unlike conventional ventilation or basic heat exchangers, RenewAire moderates not only the temperature but the humidity content of incoming air, limiting humidity swings and associated biologic growths.

## *Optimum Cold Weather Performance*

Recaptures heat otherwise lost to exhaust air while controlling humidity extremes. This greatly reduces the demand on heating equipment - lowering both initial costs and energy bills. Also protects heating coils from freeze damage.

## *Optimum Warm Weather Performance*

Pre-cools and dehumidifies the fresh airstream by transfer of heat and humidity to the exhaust airstream. This greatly reduces air conditioning demand - lowering both initial costs and energy bills. On retrofits, the ventilation rate of existing A/C equipment can be as much as doubled.

## *Energy Saved = Dollars Saved*

RenewAire's all-weather performance can cut annual energy bills for heating, cooling and dehumidification of ventilation air by 50% or more.



*Indoor Air Quality Problems Solved!*



*Ideal for Hot or Cold Environments*

## *Catalog Page Reference*

2	<b>Residential Products</b>	36	EV450RT
		38	HE1XRT
4	BR70	40	HE1XRTC
5	BR130	42	HE2XRT
6	EV70	44	HE2XRTC
7	EV130	46	HE3XRT
8	EV200	48	HE3XRTC
9	EV300	50	HE4XRT
10	<b>Commercial Indoor Products</b>	52	HE4XRTC
12	EV450IN	54	HE6XRT
14	HE1XINH	56	HE8XRT
16	HE1XINV	58	<b>Applied Products</b>
18	HE2XINH	60	CA-Series
20	HE2XINV	62	PA-Series
22	HE3XINH	64	Commercial Controls
24	HE3XINV	66	HVI Certified
26	HE4XINH	67	AHRI Certified
28	HE4XINV	67	CA/PA Model Number Guide
30	HE6XIN	68	EV/HE Model Number Guide
32	HE8XIN	69	Company History
34	<b>Commercial Outdoor Products</b>		

For Technical Support E-mail: [Support@RenewAire.com](mailto:Support@RenewAire.com)

To Place an Order E-mail: [RenewAireOrders@RenewAire.com](mailto:RenewAireOrders@RenewAire.com)

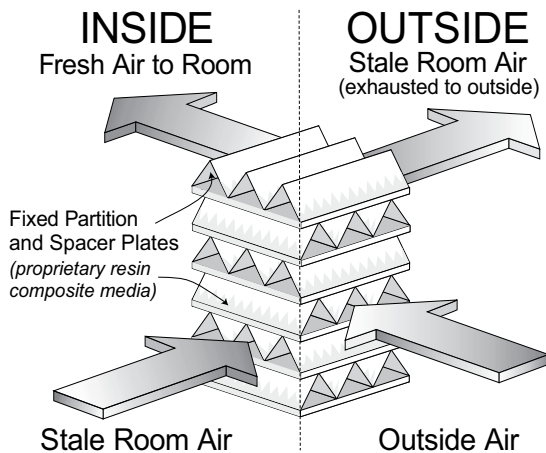

## ***The Static-Plate Core is the Key!***

Since the early 1980's, RenewAire has pioneered the use of the patented Lossnay (*Registered trademark of Mitsubishi Electric Corporation*) exchange core throughout the Americas. Listed below are some of the many reasons why this technology has become the ERV system preferred by leading HVAC professionals around the world.

## ***Positive Airstream Separation***

In the RenewAire core, fresh air never comes in contact with exhaust air passages. Hydroscopic resin plates separate the two airstreams so effectively that AHRI certifies zero exhaust air transfer at normal, balanced operating conditions. As a result, RenewAire is perfect for controlled exhaust applications such as toilet areas, as well as for food service and health care occupancies.

## **G5 Enhanced Humidity Transfer**

*RenewAire is proud to introduce the fifth generation energy recovery ventilation (ERV) core.*

- *Over 22% more humidity transfer at AHRI summer conditions*
- *reduced pressure drop - among the lowest for static-plate ERV*

*HE1X = 0.65" @ 750 SCFM  
EV450 = 0.6" @ 450 SCFM*

Try RenewAire's  
**ERV Calculation Software**  
at [www.ervcalc.renewaire.com](http://www.ervcalc.renewaire.com)

## ***No Condensate or Active Defrost***

Direct water vapor transfer, driven by vapor pressure, eliminates condensation - and frosting - in virtually all applications and climate zones. No condensation allows for closer plate spacing, resulting in higher efficiencies and easier installations. It also means no need for the dampers or electrical defrost elements that reduce ventilation and rob energy efficiency in competing technologies.

## ***Maintenance - Nothing Could Be Easier***

The scheduled maintenance for RenewAire is so simple, it can be performed by any janitorial staff. No expensive service contracts are necessary because there is no wheel disassembly and washing, no seal or belt adjustments and no complex controls to calibrate. The result is the lowest maintenance cost of any ERV.

## ***The Unbeatable RenewAire Warranty***

An investment in RenewAire is protected by a 10-year core warranty (2 years on balance of the unit). This commitment - twice as long as coverage on the best wheel products - speaks volumes about RenewAire's reliability, durability and consistently high performance.

## ***Award-Winning Service and Support***

RenewAire's team of professionals knows ERV. And our nationwide network of Sales Reps and quality Distributors are ready to serve you locally. When you call our support number, you'll talk to a knowledgeable factory expert - someone who knows not only our product line, but the best ways to integrate RenewAire with your preferred lines of heating and air conditioning equipment.

RenewAire's remarkable performance is independently certified by:



- Commercial quality, ducted equipment sized to meet required ventilation rates for homes and small commercial buildings.
- Static-plate technology makes total energy savings practical for small-capacity systems.
- May be mounted in any orientation.
- Quiet, powerful blowers eliminate the need for air balancing in most applications.
- Positive airstream separation that is critical for smoking environments and bathroom exhaust.
- No condensate pan or drain required.
- Easiest maintenance of any ERV.
- Performance certified by HVI.
- Ten year core warranty.

## Central Exhaust - Use EV Series

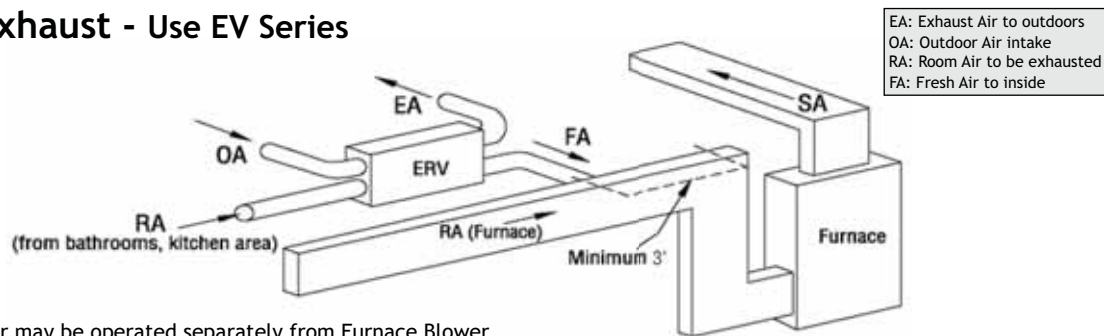

NOTE: ERV Blower may be operated separately from Furnace Blower

## General Exhaust - EV Series (or BR Series mounted to furnace return air which requires furnace blower interconnect)

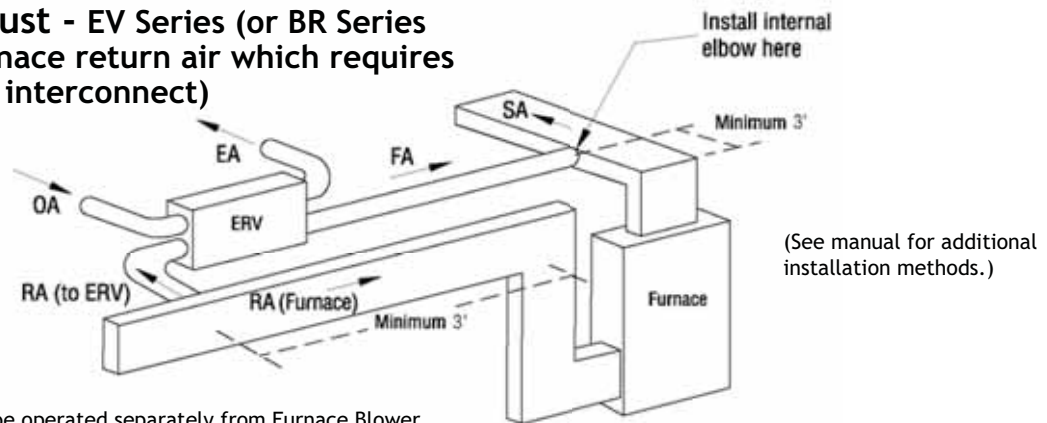

NOTE: ERV Blower may be operated separately from Furnace Blower



### PTL Control

- primary control for EV70, EV130, EV200 & EV300
- runs unit an adjustable amount of time each hour
- two wire, low voltage connection to ERV



### PBL Control

- push button control turns on unit from bathrooms or other intermittent exhaust locations
- 20 minute run-time with one touch
- push 2x for 40 or 3x for 60 minutes
- two wire, low voltage connection to PTL Control



### FM Control

- alternate primary control for EV70, EV130, EV200 & EV300
- wires to EV unit and either thermostat or furnace control to turn on furnace blower
- six wire, low voltage connection

# Residential Energy Recovery Ventilators: BR70, BR130, EV70, EV130, EV200 and EV300

## Part I - General

### A. Product Specification

1. Energy Recovery Ventilator (ERV) shall be a packaged unit as manufactured by RenewAire and shall transfer both heat and humidity using static plate core technology.

### B. Quality Assurance

1. The energy recovery ventilator shall be Certified by the Home Ventilating Institute (HVI) under CSA 439. Both a heating and a cooling test must be run to demonstrate year round energy recovery.

2. Manufacturer shall be able to provide evidence of independent testing of the core by Underwriters Laboratory (UL), verifying a maximum flame spread index (FSI) of 25 and a maximum smoke developed index (SDI) of 50 thereby meeting NFPA 90A and NFPA 90B requirements for materials in a compartment handling air intended for circulation through a duct system. The method of test shall be UL Standard 723.

3. Unit shall be Listed under UL 1812 Standard for Ducted Air to Air Heat Exchangers. The unit must pass commercial flammability requirements and shall not be labeled "For Residential Use Only".

4. The ERV core shall be warranted to be free of manufacturing defects and to retain its functional characteristics, under circumstances of normal use, for a period of ten years from the date of purchase. The balance-of-unit shall be warranted to be free of manufacturing defects and to retain its functional characteristics, under circumstances of normal use, for a period of two years from the date of purchase.

## Part II - Performance

### A. Energy Transfer

The ERV shall be capable of transferring both sensible and latent energy between airstreams. Latent energy transfer shall be accomplished by direct water vapor transfer from one airstream to the other, without exposing transfer media in succeeding cycles directly to the exhaust air and then to the fresh air.

### B. Passive Frost Control

The ERV core shall perform without condensing or frosting under normal operating conditions (defined as outside temperatures above -10°F and inside relative humidity below 40%). Occasional more extreme conditions shall not affect the usual function, performance or durability of the core. No condensate drains will be allowed.

### C. Continuous Ventilation

Unit shall have the capacity to operate continuously without the need for bypass, recirculation, pre-heaters or defrost cycles under normal operating conditions.

### D. Positive Airstream Separation

Water vapor transfer shall be through molecular transport by hydroscopic resin and shall not be accomplished by "porous plate" mechanisms. Exhaust and fresh airstreams shall travel at all times in separate passages and airstreams shall not mix.

### E. Laminar Flow

Airflow through the ERV core shall be laminar over the products entire operating airflow range, avoiding deposition of particulates on the interior of the energy exchange plate material.

## Part III - Product

### A. Construction

1. The energy recovery component shall be of fixed-plate cross-flow construction, with no moving parts.

2. No condensate drain pans or drains shall be allowed and unit shall be capable of operating in both winter and summer conditions without generating condensate.

3. The unit case shall be constructed of 24-gauge steel, with lapped corners and zinc plated screw fasteners. The case shall be finished with textured, powder coat paint.

4. Access doors shall provide easy access to blowers, ERV cores and filters. Doors shall have an airtight compression seal using closed cell foam gaskets.

5. Case walls and doors shall be fully insulated with 1 inch, expanded polystyrene foam insulation faced with a cleanable foil face on all exposed surfaces.

6. The ERV cores shall be protected by a MERV-8 rated, spun polyester, disposable filter in both airstreams.

7. The unit shall have a line cord power connection and be supplied with an internal 24 VAC transformer and relay.

8. Standby power draw shall not exceed 1 Watt for the unit along with an optional automatic control.

### B. Options *(Select options based on application requirements)*

1. **For BR-Series:** Through the wall kit and duct collar kit (automatic control is built into the unit standard).

2. **For EV-Series:** Controls including proportional run time, push button and furnace interlock and a variety of weather hoods.

## Part IV - Installation

### A. Unit Location

1. Locate and orient unit to provide the shortest and most straight duct connections. Provide service clearances as indicated on the plans. Locate units distant from sound critical occupancies.

2. Use integral mounting flange and hanging bar system to mount the unit to a structurally suitable surface. The units may be mounted in any orientation.

### B. Vibration Isolation

1. Utilize factory supplied vibration isolation kit following instructions.

2. Provide flexible duct connections at unit duct flanges.

### C. Duct Design

1. All ductwork shall be designed, constructed, supported and sealed in accordance with SMACNA HVAC Duct Construction Standards and pressure classifications.

2. At a minimum all duct runs to the outdoors shall be thermally insulated at levels appropriate to the local climate. A continuous vapor barrier shall also be provided on warm surface of the insulation.

### D. Sound Control

1. To control sound radiated from the unit:

a. Provide acoustic treatment in mechanical room walls and ceilings.

2. To control sound associated with the two blower outlets:

a. Utilize insulated, flexible duct.

b. In sound critical applications provide increased duct sizing and consider the use of sound attenuators.

### E. Test and Balancing

1. Test and Balancing may not begin until 100% of the installation is complete and fully functional.

2. Follow National Comfort Institute (NCI) air test and balance procedures specific to Heat Recovery Ventilator Balancing Procedure including standard reports to the owner's representative.

# BR70



## Indoor Unit

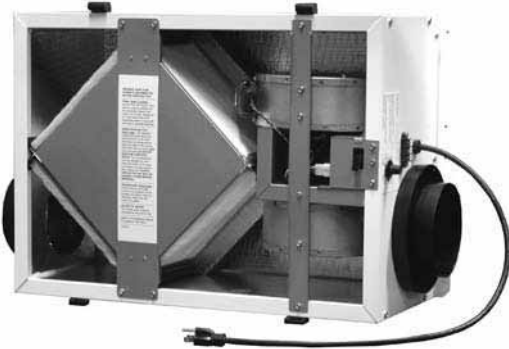

## Specifications

Ventilation Type: Static Plate, Heat and Humidity Transfer				
Typical Airflow Range: 40-70 CFM				
Number Motors: One, 0.08 hp				
V	HZ	Phase	Input Watts	FLA
120	60	Single	94 @ 69 CFM	0.9
Control Voltage: 24 VAC				
Filters: MERV 8, spun polyester media. 7 1/2" x 10 1/2" x 1"				
Weight: 39 lbs (unit), 50 lbs (in carton)				
Shipping Dimensions: 21 1/2"W x 29"L x 14 1/2"H				
Options: Thru-the-Wall Kit Duct Collar Kit				

## G4 Performance

Airflow CFM	ESP in H <sub>2</sub> O	Temp EFF%	Total EFF% Winter/Summer*
35	0.50	84	75/60
51	0.40	80	71/56
63	0.30	77	68/53
79	0.20	73	64/48
90	0.10	70	61/45

\* (See HVI certification report on page 66 for complete certified rating).

## Dimensions

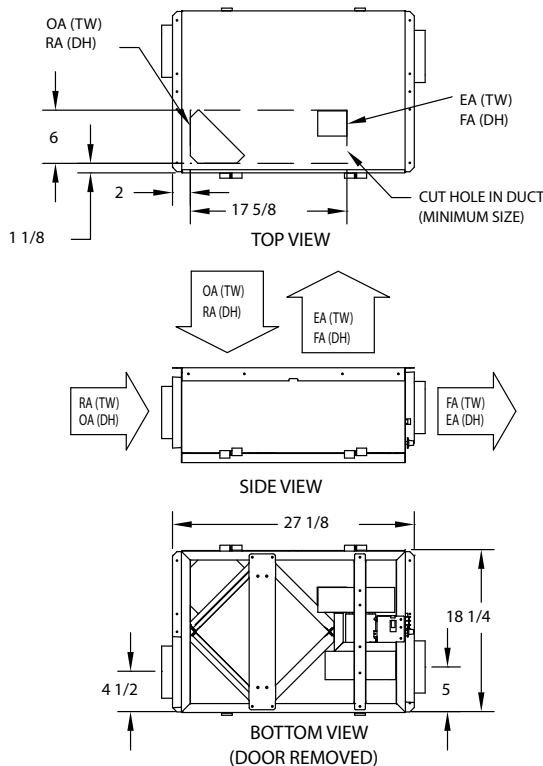

EA: Exhaust Air to outdoors  
 OA: Outdoor Air intake  
 RA: Room Air to be exhausted  
 FA: Fresh Air to inside  
 TW: Thru Wall  
 DH: Duct Hung

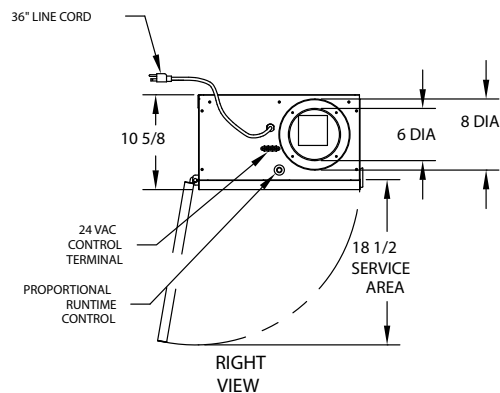

# BR130



## Indoor Unit



## G4 Performance

Airflow CFM	ESP in H <sub>2</sub> O	Temp EFF%	Total EFF% Winter/Summer*
52	0.70	83	75/60
69	0.60	80	72/57
94	0.50	76	67/52
113	0.40	73	64/48
132	0.30	70	60/44
141	0.20	68	59/43
148	0.10	67	57/41

\* (See HVI certification report on page 66 for complete certified rating).

## Specifications

Ventilation Type: Static Plate, Heat and Humidity Transfer				
Typical Airflow Range: 50-140 CFM				
Unit may be mounted in any orientation				
Number Motors: One, 0.1 hp				
V	HZ	Phase	Input Watts	FLA
120	60	Single	121 @ 124 CFM	1.3
Control Voltage: Built in proportional runtime control and switched terminals for furnace / AC interconnect				
Filters: MERV 8, spun polyester media. 10 1/2" x 10 1/2" x 1"				
Weight: 49 lbs (unit), 60 lbs (in carton)				
Shipping Dimensions: 21"W x 32"L x 17 1/2"H				
Options: Thru-the-Wall Kit Duct Collar Kit				

## Dimensions

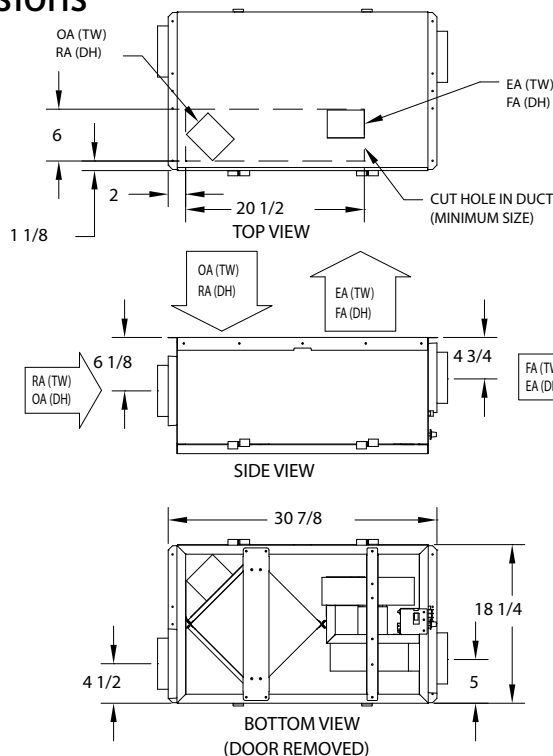

EA: Exhaust Air to outdoors  
 OA: Outdoor Air intake  
 RA: Room Air to be exhausted  
 FA: Fresh Air to inside  
 TW: Thru Wall  
 DH: Duct Hung

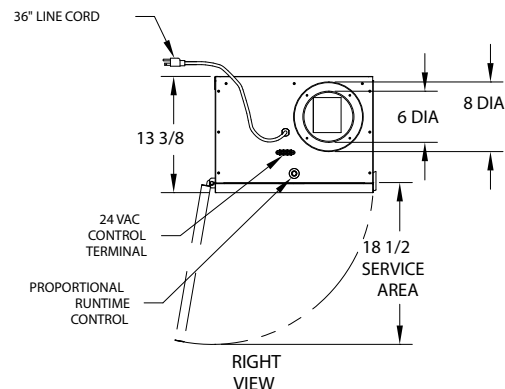

# EV70



## Indoor Unit

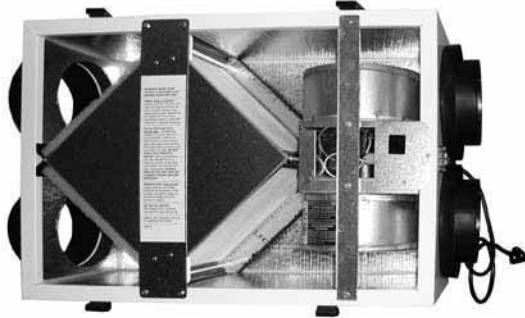

## Specifications

Ventilation Type: Static Plate, Heat and Humidity Transfer				
Typical Airflow Range: 40-70 CFM				
Unit may be mounted in any orientation				
Number Motors: One, 0.08 hp				
V	HZ	Phase	Input Watts	FLA
120	60	Single	94 @ 69 CFM	0.9
Control Voltage: 24 VAC				
Filters: MERV 8, spun polyester media. 7 1/2" x 10 1/2" x 1"				
Weight: 39 lbs (unit), 48 lbs (in carton)				
Shipping Dimensions: 21 1/2"W x 29"L x 14 1/2"H				
Options: PTL - Percentage Timer Control PBL - Push Button Point-of-Use Controls FM - Percentage Timer Control with Furnace Interlock DH24 - Dehumidistat Control Wall Caps				

## G4 Performance

Airflow CFM	ESP in H <sub>2</sub> O	Temp EFF%	Total EFF% Winter/Summer*
46	0.40	81	74/60
59	0.30	78	71/57
73	0.20	74	68/53
86	0.10	71	64/49

\* (See HVI certification report on page 66 for complete certified rating).

## Dimensions

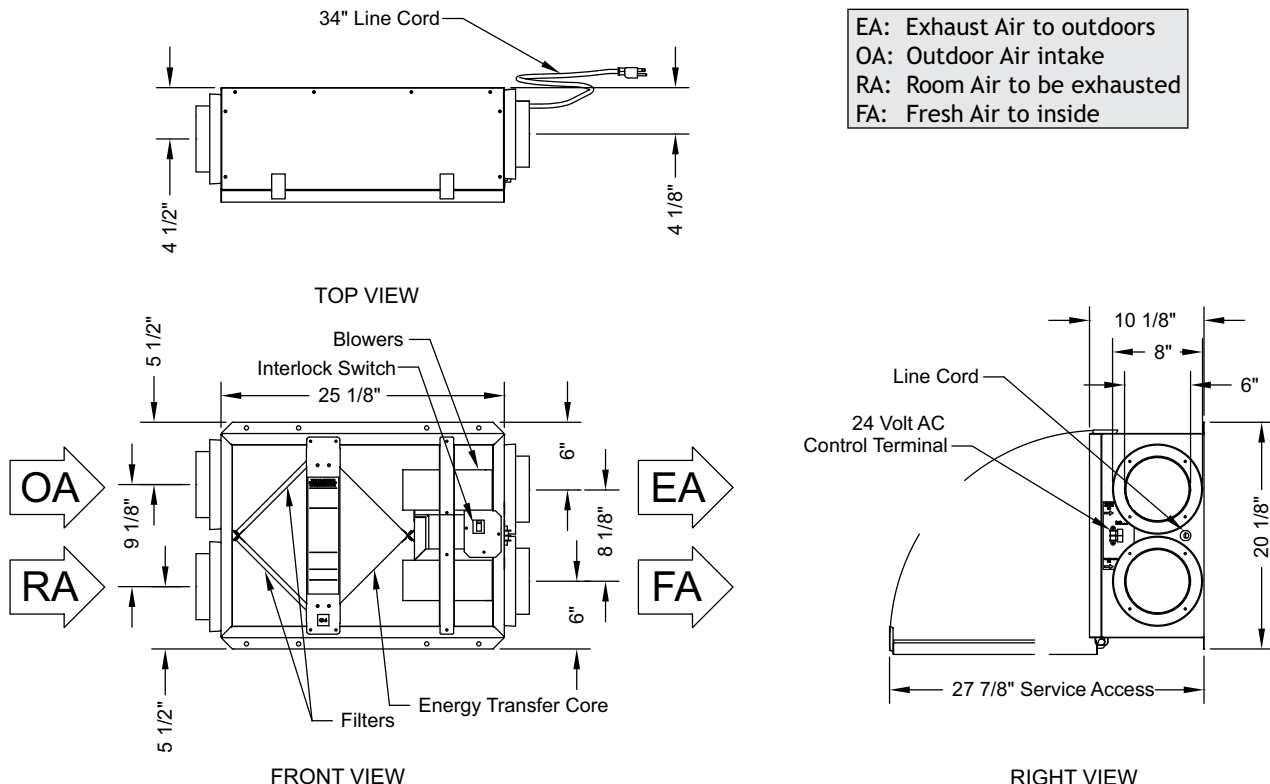



# EV130



## Indoor Unit



## Specifications

Ventilation Type: Static Plate, Heat and Humidity Transfer				
Typical Airflow Range: 50-140 CFM				
Unit may be mounted in any orientation				
Number Motors: One, 0.1 hp				
V	HZ	Phase	Input Watts	FLA
120	60	Single	121 @ 124 CFM	1.2
Control Voltage: 24 VAC				
Filters: MERV 8, spun polyester media. 10 1/2" x 10 1/2" x 1"				
Weight: 49 lbs (unit), 58 lbs (in carton)				
Shipping Dimensions: 21"W x 32"L x 17 1/2"H				
Options: PTL - Percentage Timer Control PBL - Push Button Point-of-Use Controls FM - Percentage Timer Control with Furnace Interlock DH24 - Dehumidistat Control Wall Caps				

## G4 Performance

Airflow CFM	ESP in H <sub>2</sub> O	Temp EFF%	Total EFF% Winter/Summer*
52	0.70	83	75/60
69	0.60	80	72/57
94	0.50	76	67/52
113	0.40	73	64/48
132	0.30	70	60/44
141	0.20	68	59/43
148	0.10	67	57/41

\* (See HVI certification report on page 66 for complete certified rating).

## Dimensions

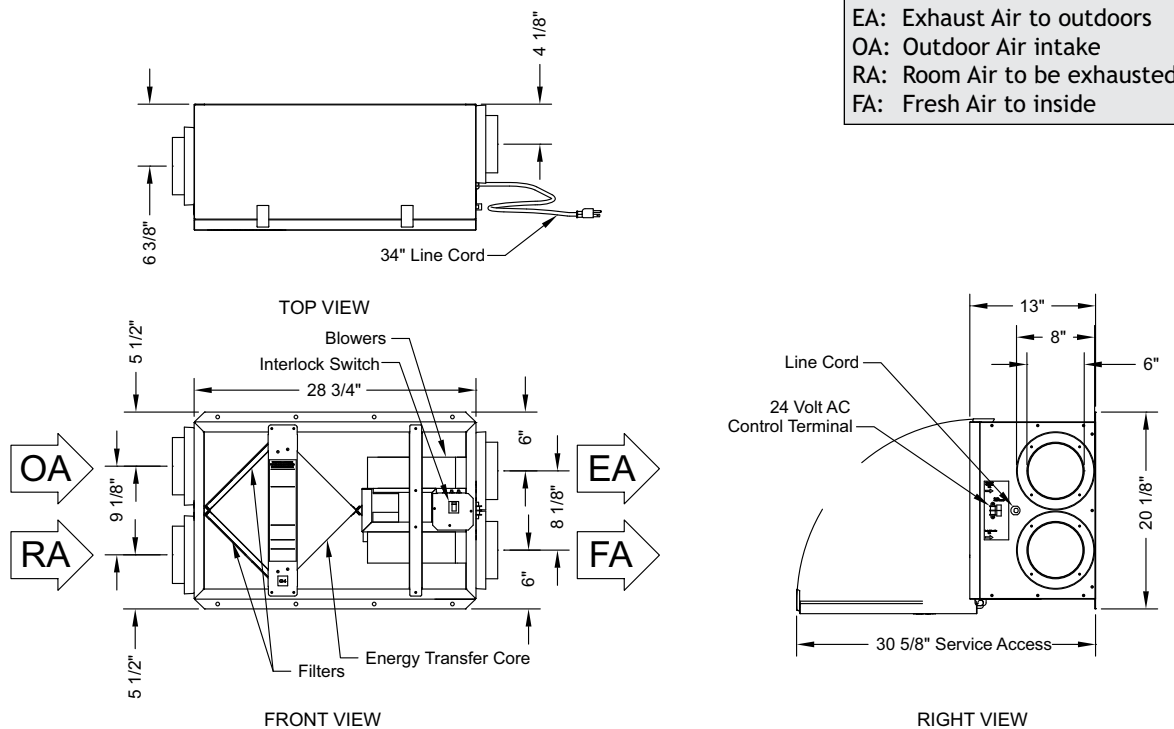

# EV200



## Indoor Unit

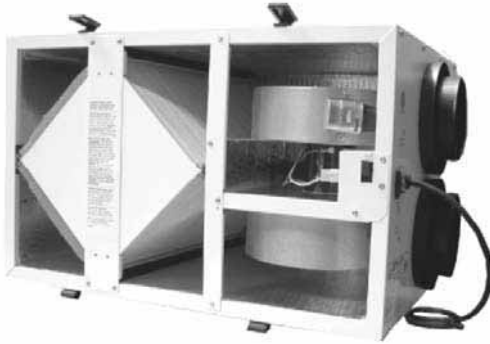

## G4 Performance

Airflow CFM	ESP in H <sub>2</sub> O	Temp EFF%	Total EFF% Winter/Summer*
122	0.70	82	74/59
149	0.65	80	72/56
168	0.50	79	70/55
176	0.40	78	69/54
186	0.30	77	68/53
192	0.20	77	68/52
200	0.10	76	67/52

\* (See HVI certification report on page 66 for complete certified rating).

## Specifications

Ventilation Type: Static Plate, Heat and Humidity Transfer				
Typical Airflow Range: 100-200 CFM				
Number Motors: One, 0.1 hp				
V	HZ	Phase	Input Watts	FLA
120	60	Single	157 @ 181 CFM	1.5
Control Voltage: 24 VAC				
Filters: MERV 8, spun polyester media. 10 1/2" x 21 3/4" x 1"				
Weight: 70 lbs (unit), 82 lbs (in carton)				
Shipping Dimensions: 21 1/2"W x 32"L x 29"H				
Options: PTL - Percentage Timer Control PBL - Push Button Point-of-Use Controls FM - Percentage Timer Control with Furnace Interlock DH24 - Dehumidistat Control Wall Caps				

## Dimensions

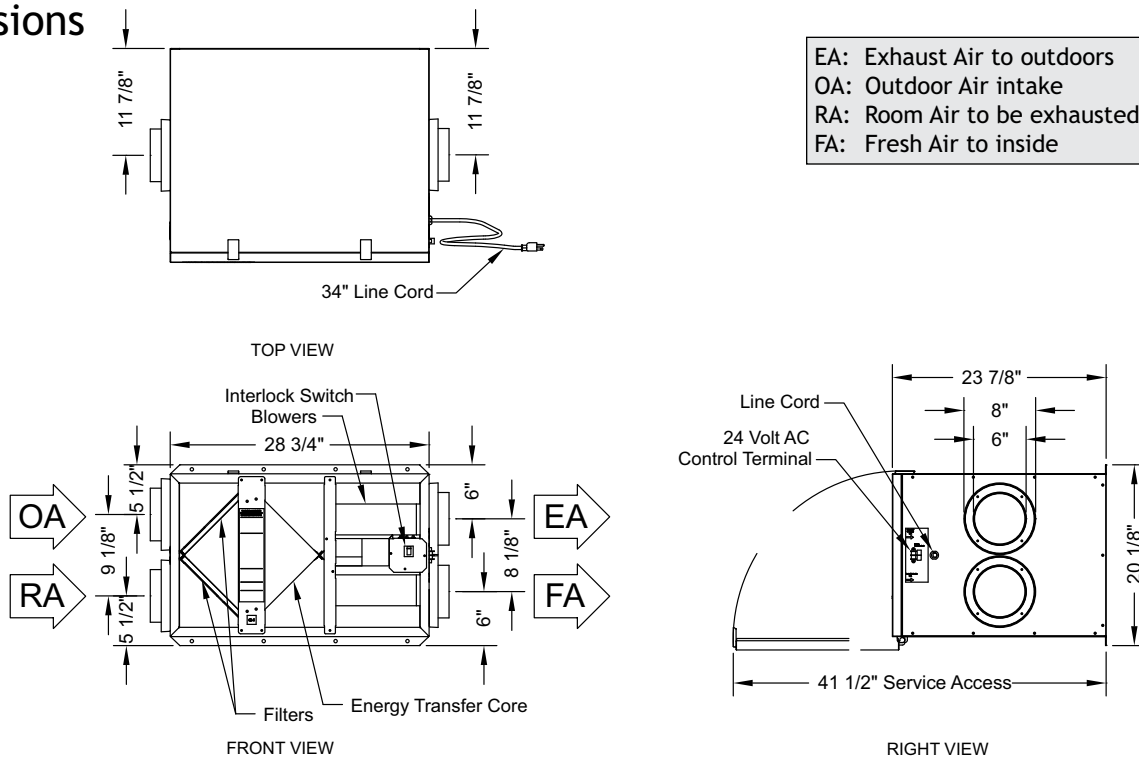

EA: Exhaust Air to outdoors  
OA: Outdoor Air intake  
RA: Room Air to be exhausted  
FA: Fresh Air to inside

# EV300



## Indoor Unit



## G4 Performance

Airflow CFM	ESP in H <sub>2</sub> O	Temp EFF%	Total EFF% Winter/Summer*
155	1.0	80	70/51
199	0.9	76	67/48
249	0.8	72	62/44
268	0.7	71	61/42
289	0.6	69	58/39
300	0.5	68	57/38
310	0.4	67	56/37

\* (See HVI certification report on page 66 for complete certified rating).

## Specifications

Ventilation Type: Static Plate, Heat and Humidity Transfer				
Typical Airflow Range: 150-300 CFM				
Number Motors: One, 0.2 hp				
V	HZ	Phase	Input Watts	FLA
120	60	Single	310 @ 293 CFM	3.3
Control Voltage: 24 VAC				
Filters: MERV 8, spun polyester media. 10 1/2" x 21 3/4" x 1"				
Weight: 72 lbs (unit), 85 lbs (in carton)				
Shipping Dimensions: 21 1/2"W x 32"L x 29"H				
Options: PTL - Percentage Timer Control PBL - Push Button Point-of-Use Controls FM - Percentage Timer Control with Furnace Interlock DH24 - Dehumidistat Control 8" Wall Caps				

## Dimensions

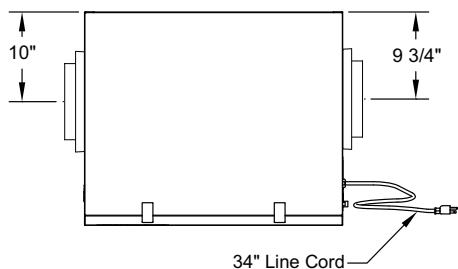

EA: Exhaust Air to outdoors  
OA: Outdoor Air intake  
RA: Room Air to be exhausted  
FA: Fresh Air to inside

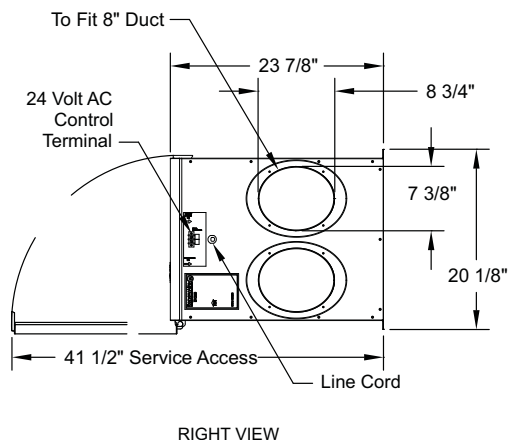
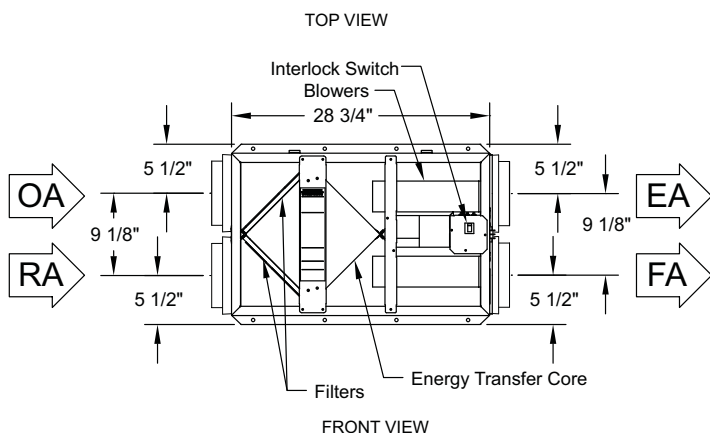

- Horizontal and vertical configuration.
- Wide range of airflow and static capacities.
- AHRI certified performance data for efficiency and cross leakage.
- UL tested flammability and smoke generation that meets NFPA 90A and 90B test standards for commercial applications.
- Easy installation and service.
- Ten year core warranty.

## RenewAire means *Trouble-Free* ERV.

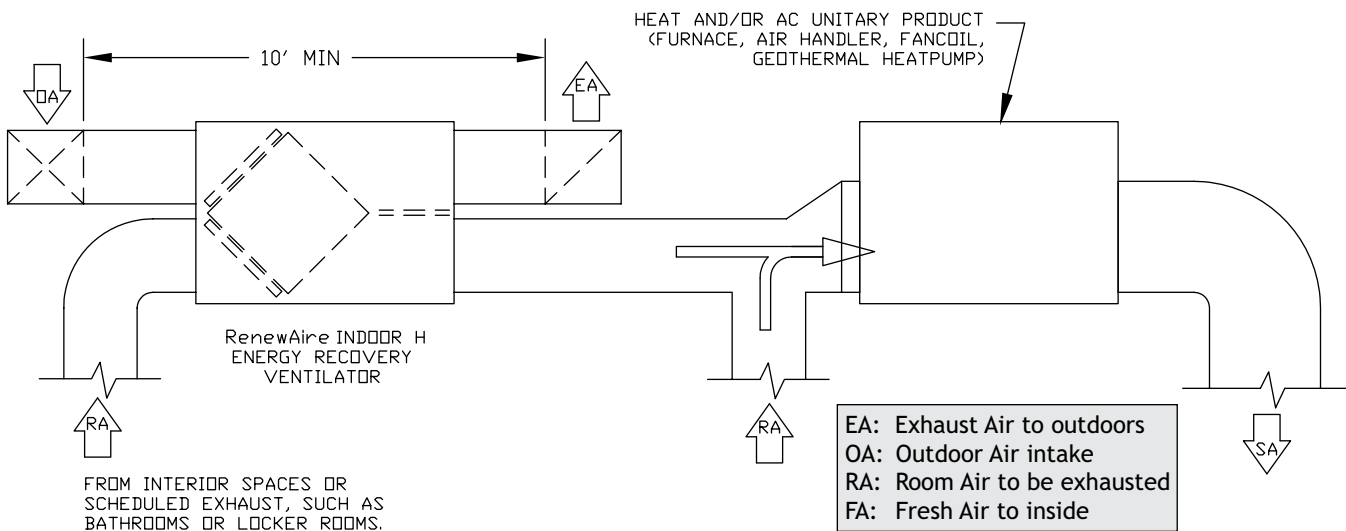
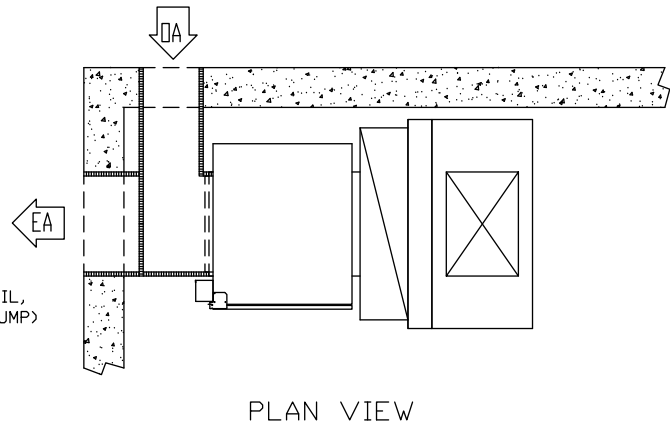
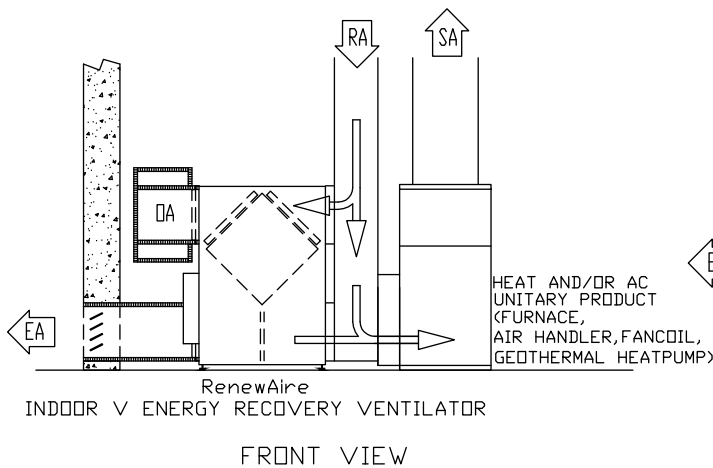

# Packaged Indoor Energy Recovery Ventilators: EV450IN, HE1XIN, HE2XIN, HE3XIN, HE4XIN, HE6XIN, HE8XIN

## Part I - General

### A. Product Specification

1. Energy Recovery Ventilator (ERV) shall be a packaged unit as manufactured by RenewAire and shall transfer both heat and humidity using static plate core technology.

### B. Quality Assurance

1. The energy recovery cores used in these products shall be third party Certified by AHRI under its Standard 1060 for Energy Recovery Ventilators. AHRI published certifications shall confirm manufacture's published performance for airflow, static pressure, temperature and total effectiveness, purge air (OACF) and exhaust air leakage (EATR). Products that are not currently AHRI Certified will not be accepted.

2. Manufacturer shall be able to provide evidence of independent testing of the core by Underwriters Laboratory (UL), verifying a maximum flame spread index (FSI) of 25 and a maximum smoke developed index (SDI) of 50 thereby meeting NFPA 90A and NFPA 90B requirements for materials in a compartment handling air intended for circulation through a duct system. The method of test shall be UL Standard 723.

3. Unit shall be Listed under UL 1812 Standard for Ducted Air to Air Heat Exchangers. (Note that a few low volume product or product configurations are not UL Listed.)

4. The ERV core shall be warranted to be free of manufacturing defects and to retain its functional characteristics, under circumstances of normal use, for a period of ten years from the date of purchase. The balance-of-unit shall be warranted to be free of manufacturing defects and to retain its functional characteristics, under circumstances of normal use, for a period of two years from the date of purchase.

## Part II - Performance

### A. Energy Transfer

The ERV shall be capable of transferring both sensible and latent energy between airstreams. Latent energy transfer shall be accomplished by direct water vapor transfer from one airstream to the other, without exposing transfer media in succeeding cycles directly to the exhaust air and then to the fresh air.

### B. Passive Frost Control

The ERV core shall perform without condensing or frosting under normal operating conditions (defined as outside temperatures above -10°F and inside relative humidity below 40%). Occasional more extreme conditions shall not affect the usual function, performance or durability of the core. No condensate drains will be allowed.

### C. Continuous Ventilation

Unit shall have the capacity to operate continuously without the need for bypass, recirculation, pre-heaters or defrost cycles under normal operating conditions.

### D. Positive Airstream Separation

Water vapor transfer shall be through molecular transport by hydroscopic resin and shall not be accomplished by "porous plate" mechanisms. Exhaust and fresh airstreams shall travel at all times in separate passages and airstreams shall not mix.

### E. Laminar Flow

Airflow through the ERV core shall be laminar over the products entire operating airflow range, avoiding deposition of particulates on the interior of the energy exchange plate material.

## Part III - Product

### A. Construction

1. The energy recovery component shall be of fixed-plate cross-flow construction, with no moving parts.

2. No condensate drain pans or drains shall be allowed and unit shall be capable of operating in both winter and summer conditions without generating condensate.

3. The unit case shall be constructed of G90 galvanized, 20-gauge steel, with lapped corners and zinc plated screw fasteners.

4. Access doors shall provide easy access to blowers, ERV cores and filters. Doors shall have an airtight compression seal using closed cell foam gaskets.

5. Case walls and doors shall be insulated with 1 inch, 4 pound density, foil/scrim faced, high-density fiberglass board insulation, providing a cleanable surface and eliminating the possibility of exposing the fresh air to glass fibers.

6. The ERV cores shall be protected by a MERV-8 rated, 2" nominal, pleated, disposable filter in both airstreams.

7. Unit shall have single-point power connection and a single-point 24 VAC contactor control connection (except Inverter Ready units that have terminal connections for an independent inverter for each airstream).

8. Blower motors shall be EPACT compliant for energy efficiency and be thermally protected or supplied with external starters.

9. Blowers shall be quiet running, forward curve type and be either direct drive or belt drive. HE6X and HE8X units use backward incline, belt drive blower packages. Belt drive motors shall be provided with adjustable pulleys and motor mounts allowing for proper belt tensioning.

### B. Options (Select options based on application requirements.)

1. Provide unit and duct connection orientation per project schedule.

2. Provide double wall construction with 24-gauge galvanized steel liner.

3. Units are available single or three phase at a full range of operating voltages. See project schedule.

4. Provide motor horsepower as specified in project schedule.

5. Provide "inverter-ready" units which include shielded power wiring and terminal connections for inverters (inverters provided and installed by others).

6. Provide factory installed fused disconnects.

7. Provide factory installed non-fused disconnects.

8. Provide factory installed transformer/relay package to supply a 24 VAC power source.

9. Provide factory installed filter monitors for each airstream.

# EV450IN



## Indoor Unit



## Specifications

Ventilation Type: Static Plate, Heat and Humidity Transfer			
Typical Airflow Range: 200-500 CFM			
AHRI 1060 Certified Core: One L85			
Airflow Rating Points (for AHRI): 450 CFM and 338 CFM			
Motors: One, 0.6 hp (Single Phase) One, 0.5hp (Three Phase)			
V	HZ	Phase	FLA
115	60	Single	7.0
208-230	60	Single	3.5
277	60	Single	2.4
208-230	60	Three	1.7-1.5
460	60	Three	0.8
Control Voltage: 24 VAC			
Filters: Two total, MERV 8, 2" pleated, 14" x 20" nominal size			
Weight: 141 lbs (unit), 160 lbs (in carton), up to 3 units on 50 lb pallet			
Shipping Dimensions: 37 1/2" W x 48" L x 17" H			
Options: 45EVHB - Hanging Bracket, Foot Kit 45EVDF - Rectangular 12" x 8" Flange Kit (2 in kit) 45EVT10 - 10" Round Transition Kit (2 in kit)			

## G5 Performance

Airflow CFM	ESP in H <sub>2</sub> O	Watts		Temp EFF%	Total EFF% Winter/Summer*
		1P	3P		
225	1.25	335	181	81	76/66
338	1.00	420	278	77	71/61
380	0.90	470	340	75	69/59
450	0.65	550	430	73	66/56
540	0.25	640	540	70	62/52
575	0.00	690	610	69	61/51
600	-0.25	735	664	68	60/50

\*At AHRI 1060 standard conditions  
(See certified data on page 67 for core components.)

# EV450IN UNIT DIMENSIONS

EA: Exhaust Air to outdoors  
 OA: Outdoor Air Intake  
 RA: Room Air to be exhausted  
 FA: Fresh Air to inside

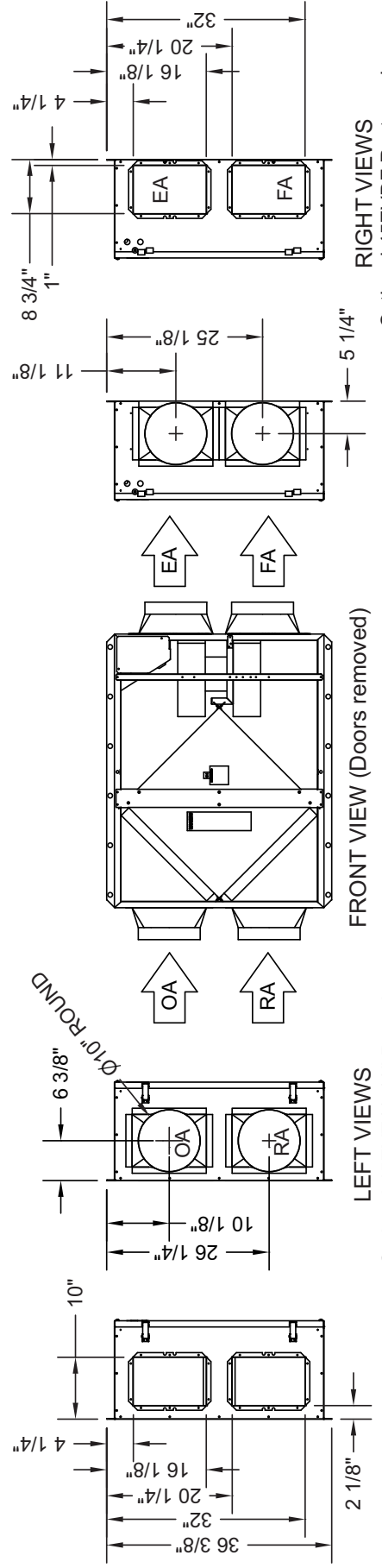
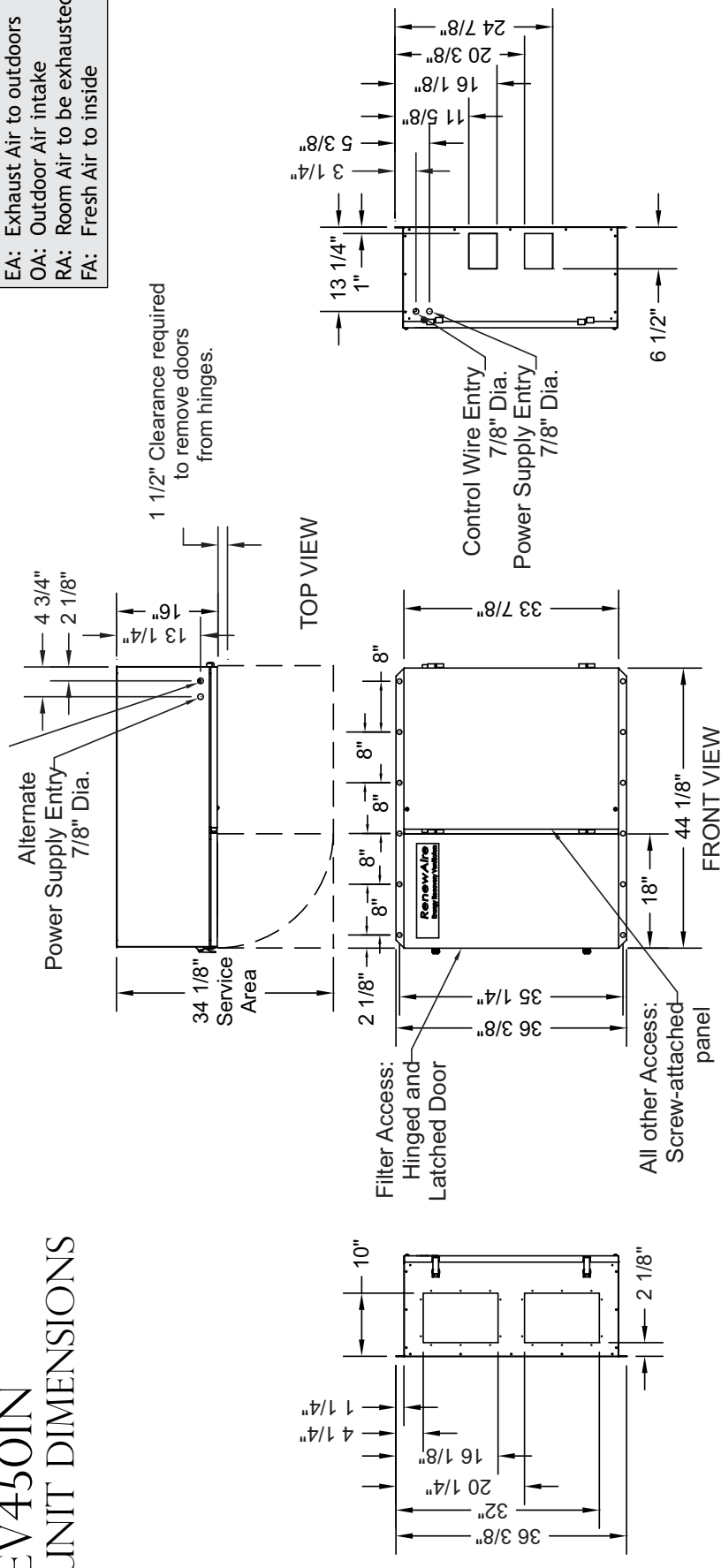

# HEIXINH



## Indoor Unit



## Specifications

Ventilation Type: Static Plate, Heat and Humidity Transfer					
Typical Airflow Range: 250-925 CFM					
AHRI 1060 Certified Core: One L125-00					
Airflow Rating Points (for AHRI): 750 CFM and 560 CFM					
Number Motors: Two					
V	HZ	Phase	FLA	Min. Cir. Amps	Max. Fuse Size
115	60	Single	8.6	19.4	25
208-230	60	Single	4.3	9.7	15
277	60	Single	2.4	5.4	15
208-230	60	Three	2.1	5.2	15
460	60	Three	1.1	2.6	15
Control Voltage: 24 VAC					
Filters: Two total, MERV 8, 2" pleated, 20" x 20" nominal size					
Weight: 211 lbs (unit), 250 lbs (shipping weight)					
Shipping Dimensions: 44" W x 56" L x 27" H					

## G5 Performance

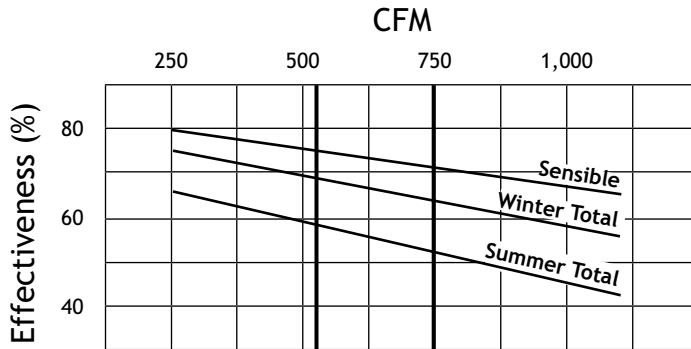

\*At AHRI 1060 standard conditions  
(See certified data on page 67 for core components.)

## Airflow Performance

Motor HP Phase	External Static Pressure (Inches Water Column)						
	0.0	0.25	0.5	0.75	1.0	1.25	1.5
0.75 (Two DD) Single Phase	970 CFM 1,490 Watts	925 CFM 1,375 Watts	860 CFM 1,270 Watts	795 CFM 1,160 Watts	720 CFM 1,030 Watts	635 CFM 950 Watts	350 CFM 750 Watts
0.75 (Two DD) Three Phase	1,030 CFM 1,220 Watts	1,010 CFM 1,210 Watts	975 CFM 1,160 Watts	880 CFM 1,050 Watts	800 CFM 990 Watts	700 CFM 850 Watts	530 CFM 720 Watts



# HEIXINH UNIT DIMENSIONS

EA: Exhaust Air to outdoors  
 OA: Outdoor Air Intake  
 RA: Room Air to be exhausted  
 FA: Fresh Air to inside

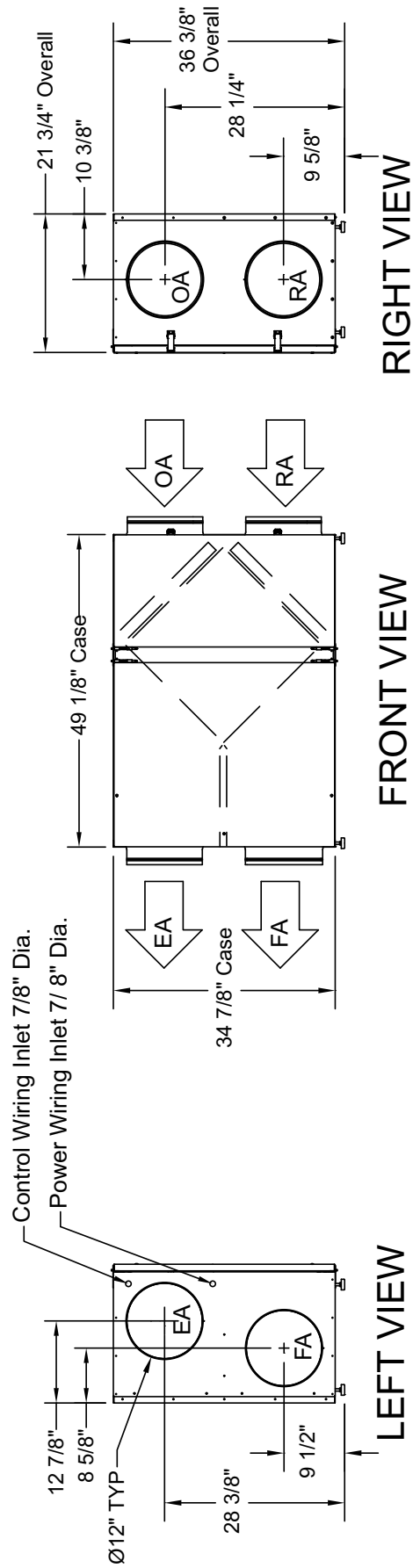
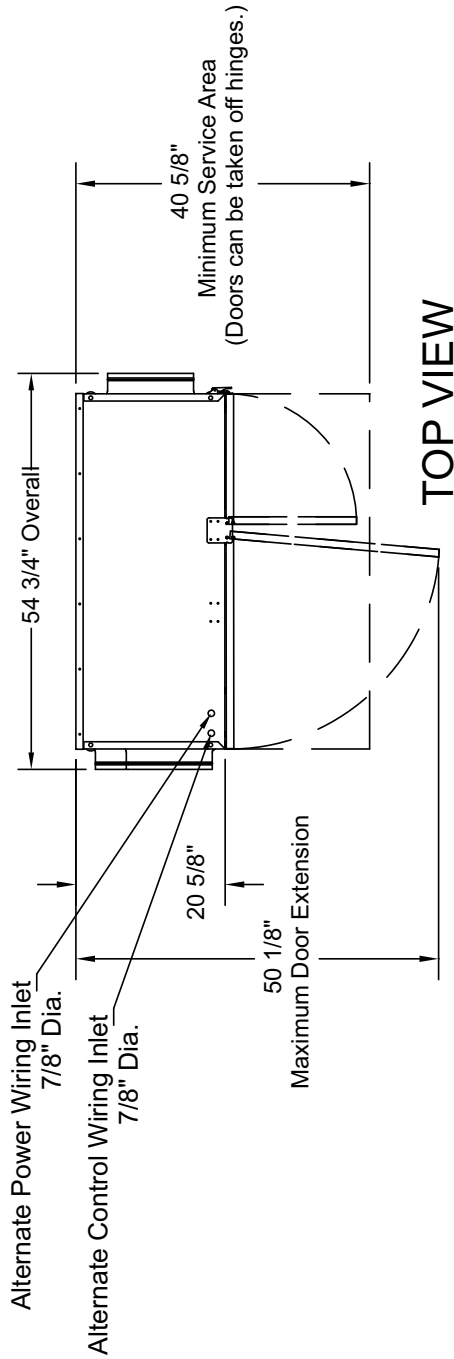

# HEIXINV



## Indoor Unit

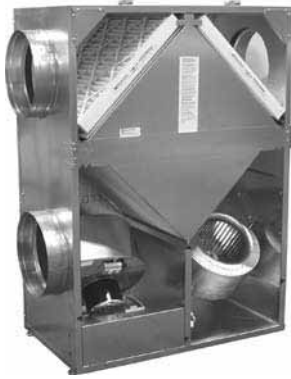

## Specifications

Ventilation Type: Static Plate, Heat and Humidity Transfer					
Typical Airflow Range: 250-925 CFM					
AHRI 1060 Certified Core: One L125-00					
Airflow Rating Points (for AHRI): 750 CFM and 560 CFM					
Number Motors: Two					
V	HZ	Phase	FLA	Min. Cir. Amps	Max. Fuse Size
115	60	Single	8.6	19.4	25
208-230	60	Single	4.3	9.7	15
277	60	Single	2.4	5.4	15
208-230	60	Three	2.1	5.2	15
460	60	Three	1.1	2.6	15
Control Voltage: 24 VAC					
Filters: Two total, MERV 8, 2" pleated, 20" x 20" nominal size					
Weight: 211 lbs (unit), 250 lbs (shipping weight)					
Shipping Dimensions: 44" W x 56" L x 27" H					

## G5 Performance

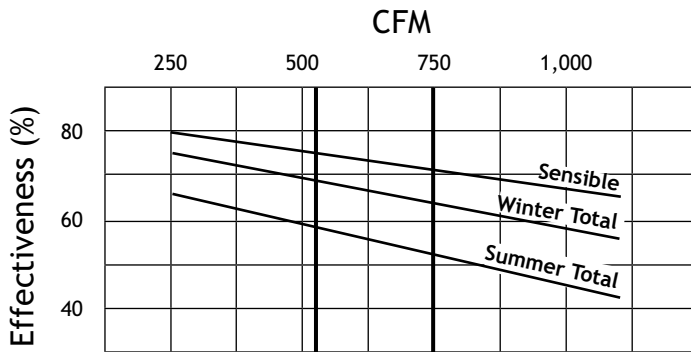

\*At AHRI 1060 standard conditions  
(See certified data on page 67 for core components.)

## Airflow Performance

Motor HP Phase	External Static Pressure (Inches Water Column)						
	0.0	0.25	0.5	0.75	1.0	1.25	1.5
0.75 (Two DD) Single Phase	970 CFM 1,490 Watts	925 CFM 1,375 Watts	860 CFM 1,270 Watts	795 CFM 1,160 Watts	720 CFM 1,030 Watts	635 CFM 950 Watts	350 CFM 750 Watts
0.75 (Two DD) Three Phase	1,030 CFM 1,220 Watts	1,010 CFM 1,210 Watts	975 CFM 1,160 Watts	880 CFM 1,050 Watts	800 CFM 990 Watts	700 CFM 850 Watts	530 CFM 720 Watts

# HEIXINV UNIT DIMENSIONS

EA: Exhaust Air to outdoors  
 OA: Outdoor Air Intake  
 RA: Room Air to be exhausted  
 FA: Fresh Air to inside

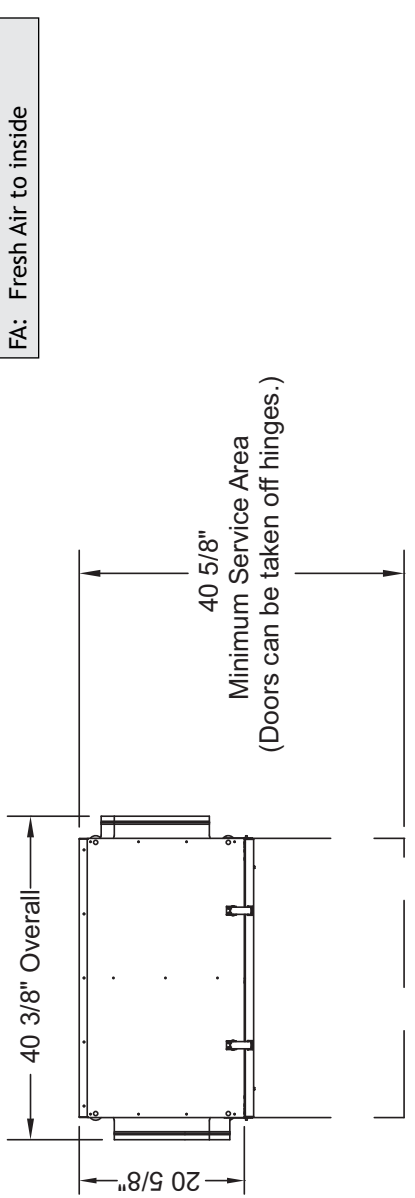

TOP VIEW

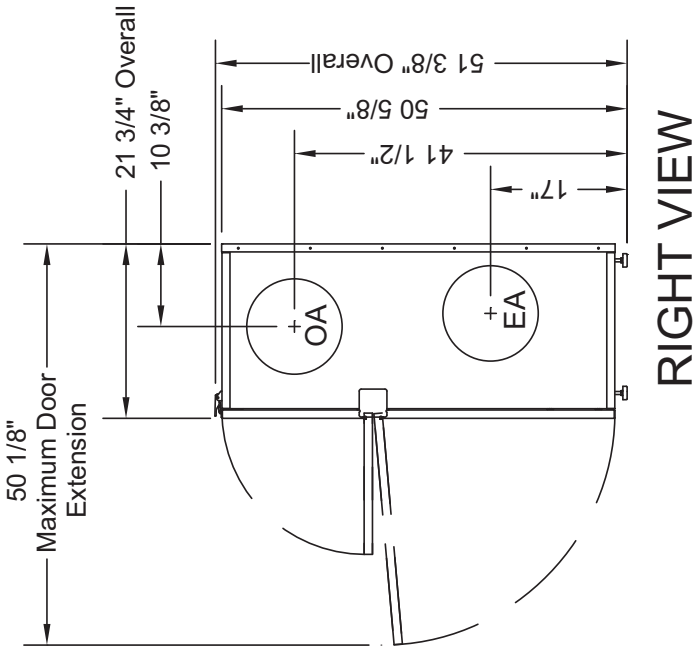

RIGHT VIEW

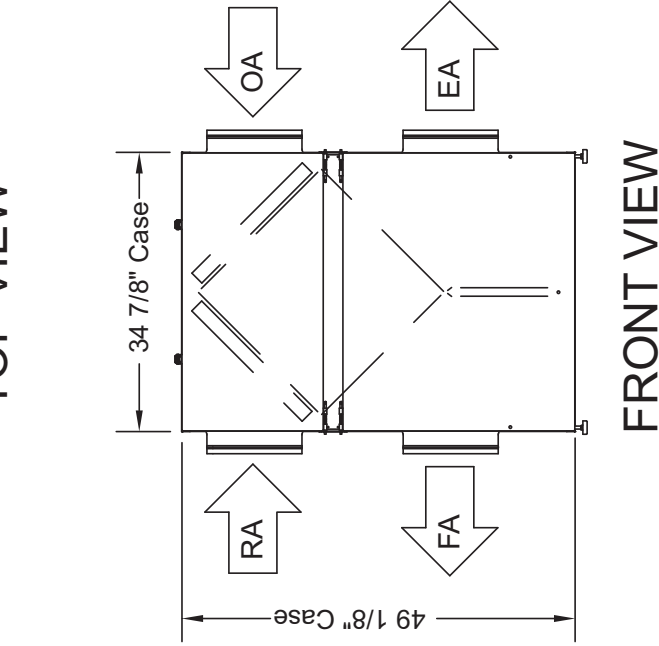

FRONT VIEW

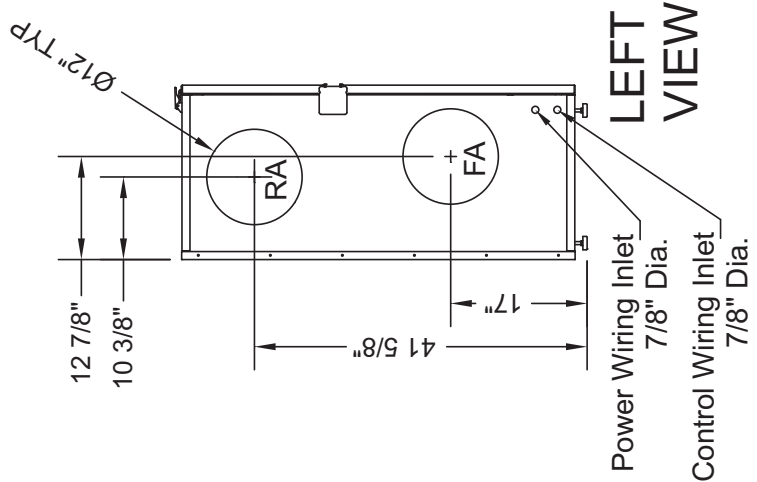

LEFT VIEW

# HE2XINH



## Indoor Unit

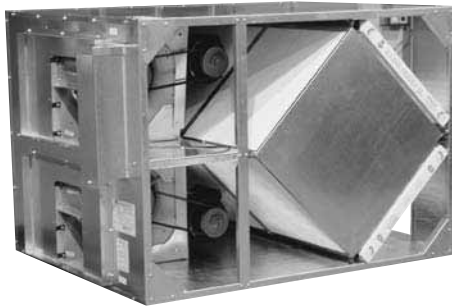

## Specifications

Ventilation Type: Static Plate, Heat and Humidity Transfer						
Typical Airflow Range: 500-2,000 CFM						
AHRI 1060 Certified Core: Two L125-00						
Airflow Rating Points (for AHRI): 1,500 CFM and 1,120 CFM						
Number Motors: Direct Drive (DD) Four, Belt Drive (BD) Two						
Drive HP	Volts	HZ	Phase	FLA	Min. Cir. Amps	Max. Fuse Size
DD 0.75	115	60	Single	8.6	36.6	45
	208-230	60	Single	4.3	18.3	20
	277	60	Single	2.4	10.2	15
	208-230 460	60 60	Three Three	2.1 1.1	9.8 4.9	15 15
BD 1.5	208-230	60	Single	9.3-9.0	20.9	30
	208-230	60	Three	4.8-4.8	10.8	15
	460	60	Three	2.4	5.4	15
	575	60	Three	1.8	4.1	15
BD 2	208-230	60	Single	11.3-10.5	25.4	35
	208-230	60	Three	6.2-6.2	14.0	20
	460	60	Three	3.1	7.0	15
	575	60	Three	2.3	5.2	15
Control Voltage: 24 VAC						
Filters: Four total, MERV 8, 2" pleated, 20" x 20" nominal size						
Weight: 414 lbs (unit), 420 lbs (shipping weight)						
Shipping Dimensions: 50" W x 62" L x 41" H						

## G5 Performance

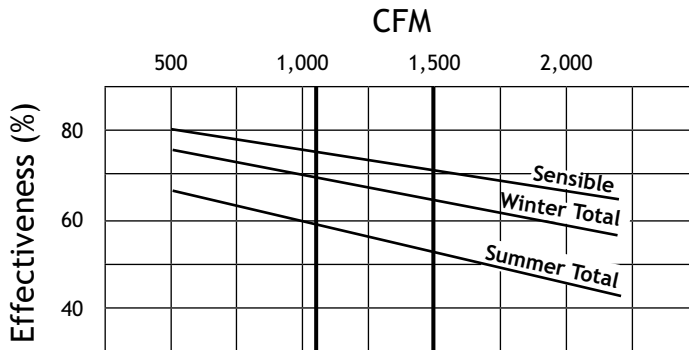

\*At AHRI 1060 standard conditions  
(See certified data on page 67 for core components.)

## Airflow Performance

Motor HP	Blower RPM Nominal	Turns Open	External Static Pressure (Inches Water Column)													
			0.0		0.25		0.5		0.75		1.0		1.25		1.5	
			CFM	BHP	CFM	BHP	CFM	BHP	CFM	BHP	CFM	BHP	CFM	BHP	CFM	BHP
0.75 (Four DD) Single Phase	N/A	N/A	1,950	0.5	1,830	0.5	1,670	0.4	1,400	0.4	1,150	0.4	700	-	-	-
	N/A	N/A	2,240	0.9	2,155	0.9	2,020	0.8	1,795	0.7	1,490	0.7	1,190	0.6	-	-
0.75 (Four DD) Three Phase	N/A	N/A	1,960	0.5	1,840	0.5	1,700	0.4	1,600	0.4	1,380	0.4	1,190	0.4	800	0.4
	N/A	N/A	2,500	0.9	2,300	0.9	2,125	0.8	1,900	0.7	1,700	0.7	1,500	0.6	1,260	0.6
1.5 (BD)	1,000	4.5	1,378	0.5	1,175	0.5	900	0.4	635	0.4	-	-	-	-	-	-
	1,230	2	1,694	0.9	1,550	0.9	1,335	0.8	1,125	0.7	1,000	0.7	500	0.6	-	-
	1,420	0	1,956	1.4	1,850	1.4	1,680	1.2	1,475	1.2	1,300	1.1	1,200	1.1	930	0.9
2 (BD)	1,220	4.5	1,681	0.9	1,530	0.9	1,315	0.7	1,100	0.7	975	0.6	-	-	-	-
	1,470	2	2,025	1.6	1,925	1.5	1,750	1.4	1,575	1.3	1,375	1.2	1,275	1.2	1,125	1.1
	1,660	0	-	-	-	-	2,000	2.0	1,900	1.9	1,750	1.8	1,570	1.7	1,475	1.7

Note: Brake Horse Power (BHP) is for one blower motor package only.

# HE2XINH UNIT DIMENSIONS

- EA: Exhaust Air to outdoors
- OA: Outdoor Air Intake
- RA: Room Air to be exhausted
- FA: Fresh Air to inside

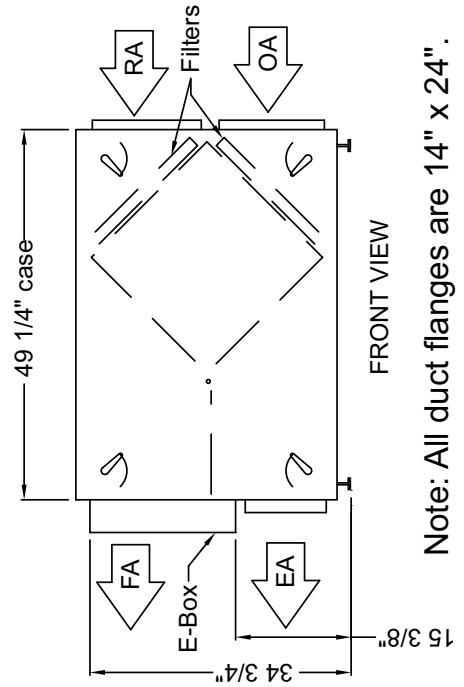
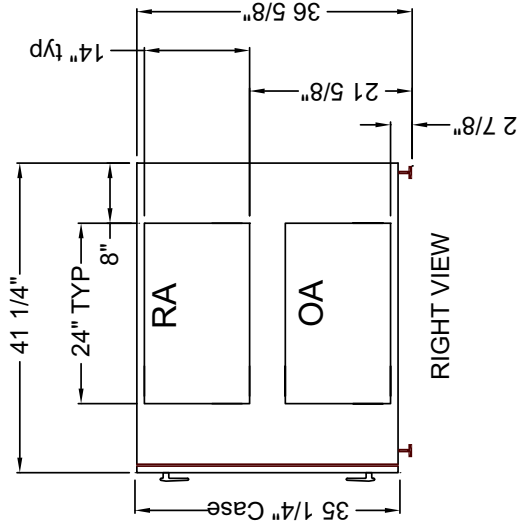
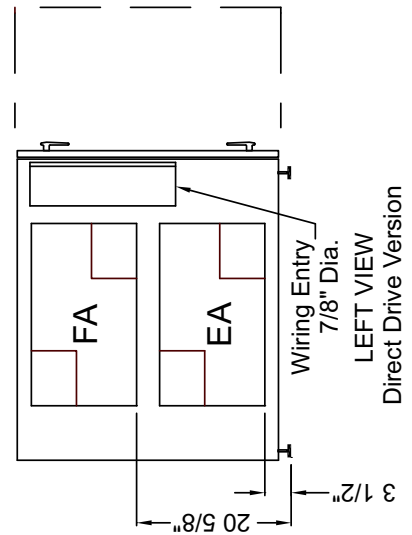
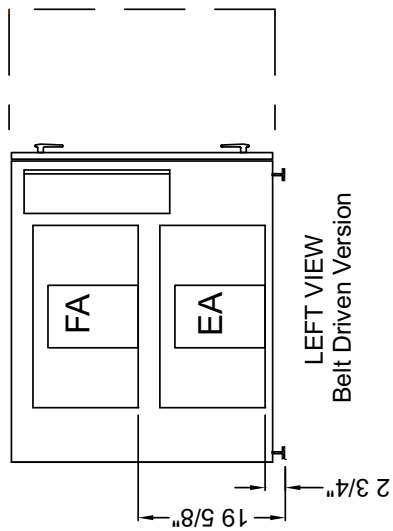
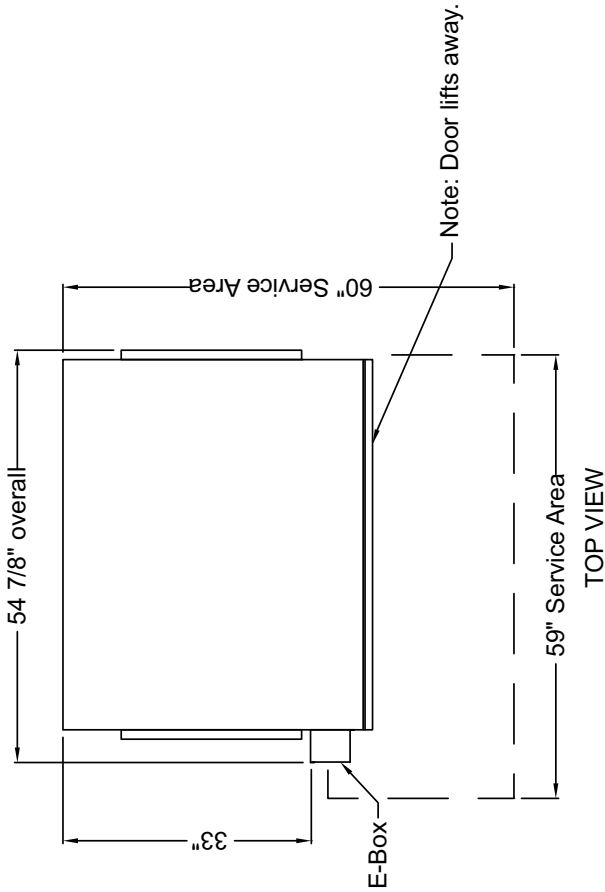

# HE2XINV



## Indoor Unit



## Specifications

Ventilation Type: Static Plate, Heat and Humidity Transfer						
Typical Airflow Range: 500-2,000 CFM						
AHRI 1060 Certified Core: Two L125-00						
Airflow Rating Points (for AHRI): 1,500 CFM and 1,120 CFM						
Number Motors: Direct Drive (DD) Four, Belt Drive (BD) Two						
Drive HP	Volts	HZ	Phase	FLA	Min. Cir. Amps	Max. Fuse Size
DD 0.75	115	60	Single	8.6	36.6	45
	208-230	60	Single	4.3	18.3	20
	277	60	Single	2.4	10.2	15
	208-230	60	Three	2.1	9.8	15
	460	60	Three	1.1	4.9	15
	208-230	60	Single	9.3-9.0	20.9	30
	208-230	60	Three	4.8-4.8	10.8	15
	460	60	Three	2.4	5.4	15
BD 1.5	575	60	Three	1.8	4.1	15
	208-230	60	Single	11.3-10.5	25.4	35
	208-230	60	Three	6.2-6.2	14.0	20
	460	60	Three	3.1	7.0	15
BD 2	575	60	Three	2.3	5.2	15
	Control Voltage: 24 VAC					
	Filters: Four total, MERV 8, 2" pleated, 20" x 20" nominal size					
	Weight: 399 lbs (unit), 420 lbs (shipping weight)					
Shipping Dimensions: 48" W x 62" L x 55" H						

## G5 Performance

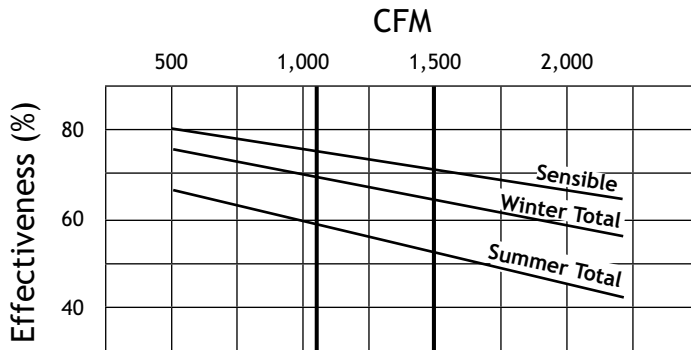

\*At AHRI 1060 standard conditions  
(See certified data on page 67 for core components.)

## Airflow Performance

Motor HP	Blower RPM Nominal	Turns Open	External Static Pressure (Inches Water Column)													
			0.0		0.25		0.5		0.75		1.0		1.25		1.5	
0.75 (Four DD) Single Phase	N/A	N/A	1,870 CFM	1,720 CFM	1,520 CFM	1,290 CFM	1,080 CFM	700 CFM	-	-	-	-	-	-	-	
	N/A	N/A	2,160 Watts	2,070 Watts	1,900 Watts	1,715 Watts	1,505 Watts	1,210 Watts	-	-	-	-	-	-	-	
0.75 (Four DD) Three Phase	N/A	N/A	1,870 CFM	1,720 CFM	1,540 CFM	1,350 CFM	1,240 CFM	1,030 CFM	800 CFM	-	-	-	-	-	-	
	N/A	N/A	2,500 Watts	2,300 Watts	2,125 Watts	1,950 Watts	1,730 Watts	1,490 Watts	1,240 Watts	-	-	-	-	-	-	
1.5 (BD)	1,000	4.5	1,378 CFM	1,175 CFM	900 CFM	635 CFM	-	-	-	-	-	-	-	-	-	
	1,230	2	1,694 CFM	1,550 CFM	1,335 CFM	1,125 CFM	1,000 CFM	500 CFM	-	-	-	-	-	-	-	
	1,420	0	1,956 CFM	1,850 CFM	1,680 CFM	1,475 CFM	1,300 CFM	1,200 CFM	930 CFM	-	-	-	-	-	-	
2 (BD)	1,220	4.5	1,681 CFM	1,530 CFM	1,315 CFM	1,100 CFM	975 CFM	430 CFM	-	-	-	-	-	-	-	
	1,470	2	2,025 CFM	1,925 CFM	1,750 CFM	1,575 CFM	1,375 CFM	1,275 CFM	1,125 CFM	-	-	-	-	-	-	
	1,660	0	-	-	2,000 CFM	1,900 CFM	1,750 CFM	1,570 CFM	1,475 CFM	-	-	-	-	-	-	

Note: Brake Horse Power (BHP) is for one blower motor package only.

# HE2XIN V UNIT DIMENSIONS

EA: Exhaust Air to outdoors  
 OA: Outdoor Air Intake  
 RA: Room Air to be exhausted  
 FA: Fresh Air to inside

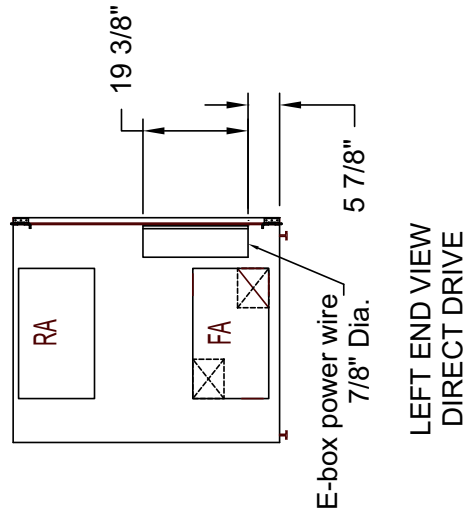
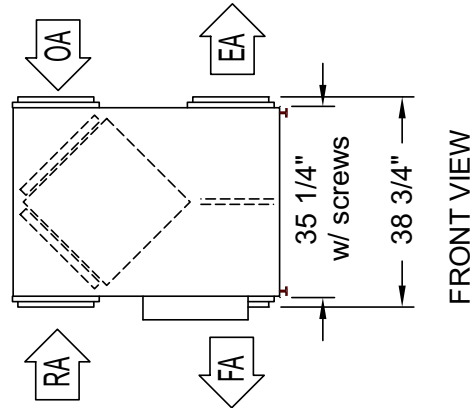
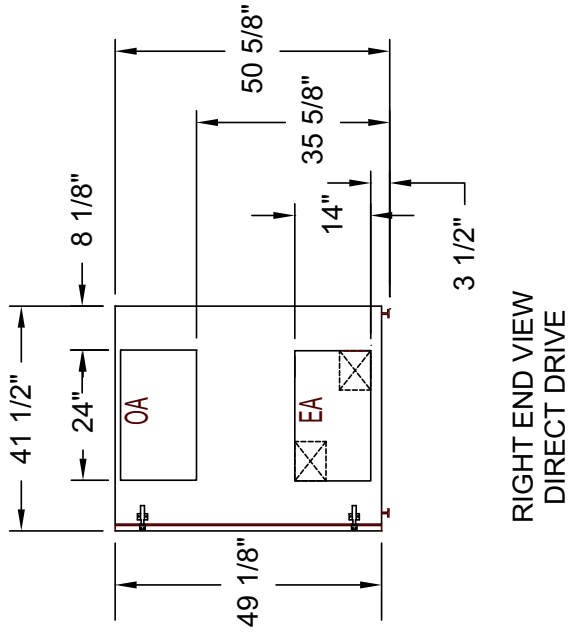
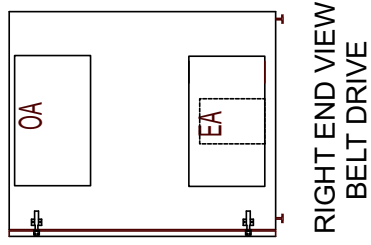
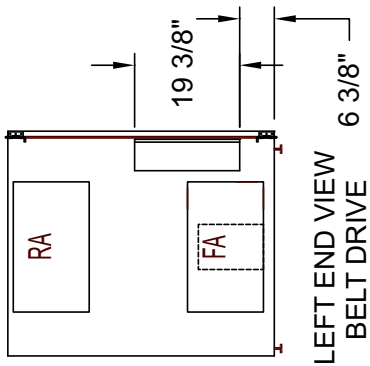
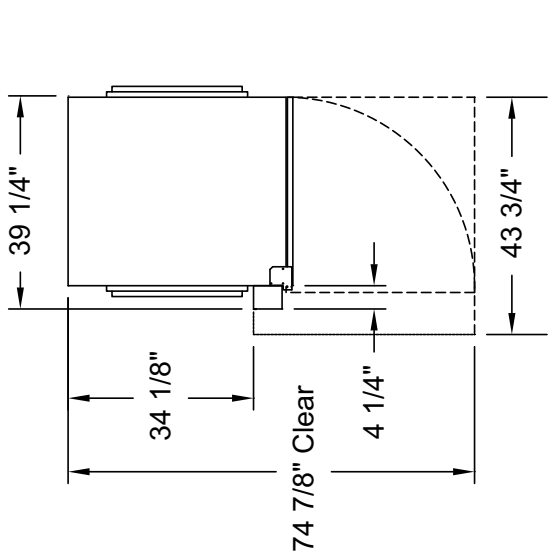

Note: All duct flanges are 14" x 24".

# HE3XINH



## Indoor Unit

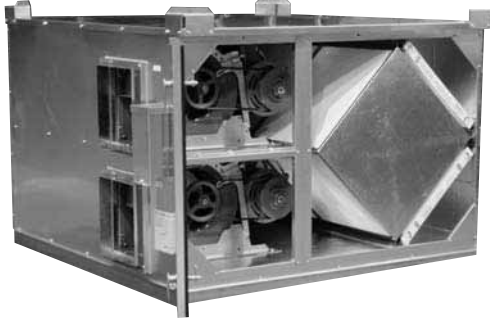

## Specifications

Ventilation Type: Static Plate, Heat and Humidity Transfer						
Typical Airflow Range: 750-3,300 CFM						
AHRI 1060 Certified Core: Three L125-00						
Airflow Rating Points (for AHRI): 2,250 CFM and 1,690 CFM						
Number Motors: Two						
HP	Volts	HZ	Phase	FLA	Min. Cir. Amps	Max. Fuse Size
2	208-230	60	Single	11.3-10.5	25.4	35
	208-230	60	Three	6.2-6.2	14.0	20
	460	60	Three	3.1	7.0	15
	575	60	Three	2.3	5.2	15
3	208-230	60	Single	13.7	30.8	45
	208-230	60	Three	9.2-8.6	20.7	30
	460	60	Three	4.3	9.7	15
	575	60	Three	3.2	7.2	15
5	208-230	60	Three	14.0-13.0	31.5	45
	460	60	Three	6.5	14.6	20
	575	60	Three	5.0	11.3	15
	Control Voltage: 24 VAC					
Filters: Six total, MERV 8, 2" pleated, 20" x 20" nominal size						
Weight: 675 lbs (unit), 700 lbs (shipping weight)						
Shipping Dimensions: 72" W x 84" L x 46" H						

## G5 Performance

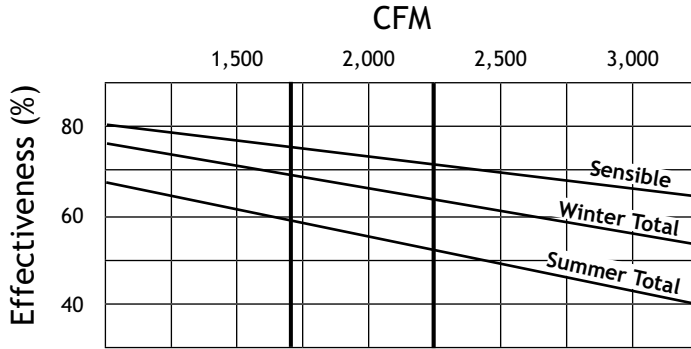

\*At AHRI 1060 standard conditions  
(See certified data on page 67 for core components.)

## Airflow Performance

Motor HP	Blower RPM Nominal	Turns Open	External Static Pressure (Inches Water Column)													
			0.0		0.25		0.5		0.75		1.0		1.25		1.5	
			CFM	BHP	CFM	BHP	CFM	BHP	CFM	BHP	CFM	BHP	CFM	BHP	CFM	BHP
2	1,095	4	2,040	1.3	1,760	1.3	1,370	1.2	920	1.1	-	-	-	-	-	-
	1,220	2	2,340	1.5	2,110	1.4	1,790	1.3	1,380	1.2	940	1.2	-	-	-	-
	1,340	0	2,590	1.8	2,370	1.7	2,130	1.6	1,760	1.4	1,310	1.3	980	1.2	-	-
3	1,345	4.5	2,420	2.3	2,280	2.2	2,090	2.1	1,760	2.0	1,280	1.9	860	1.9	-	-
	1,535	2	2,850	2.8	2,760	2.7	2,570	2.6	2,380	2.5	2,090	2.4	1,810	2.2	1,330	2.1
	1,685	0	-	-	-	-	-	-	2,660	2.9	2,470	2.7	2,280	2.6	2,000	2.4
5	1,495	6.5	2,850	3.1	2,710	3.0	2,520	2.9	2,280	2.8	2,040	2.7	1,620	2.5	1,140	2.4
	1,675	3.5	3,280	3.8	3,140	3.7	2,990	3.5	2,800	3.3	2,610	3.1	2,380	2.9	2,090	2.7
	1,855	0	-	-	-	-	3,470	4.9	3,330	4.7	3,140	4.5	3,040	4.4	2,760	4.0



# HE3XINH UNIT DIMENSIONS

EA: Exhaust Air to outdoors  
 OA: Outdoor Air Intake  
 RA: Room Air to be exhausted  
 FA: Fresh Air to inside

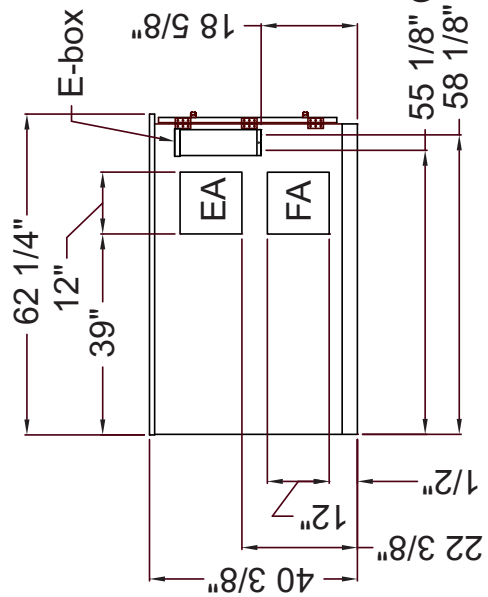
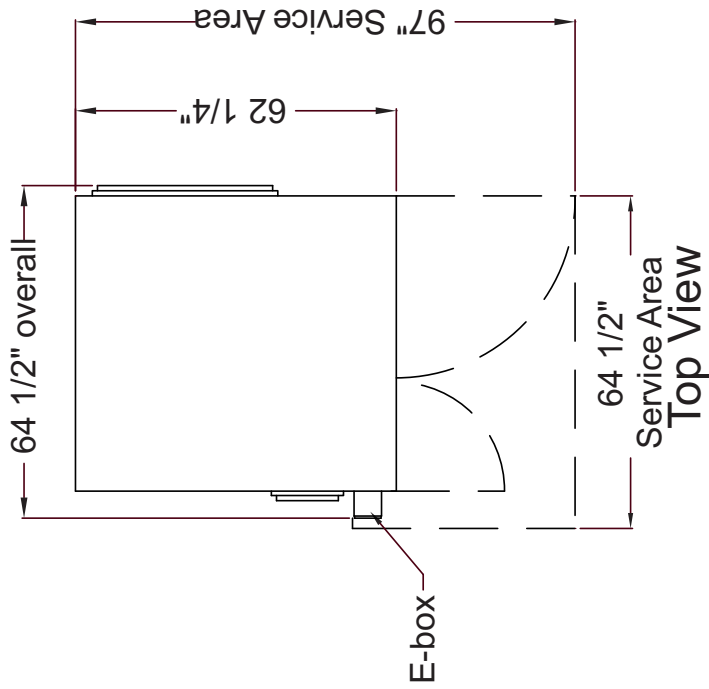

Left View

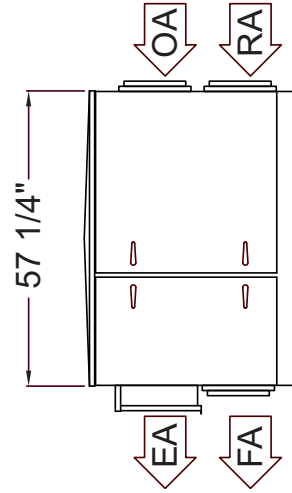

Front View

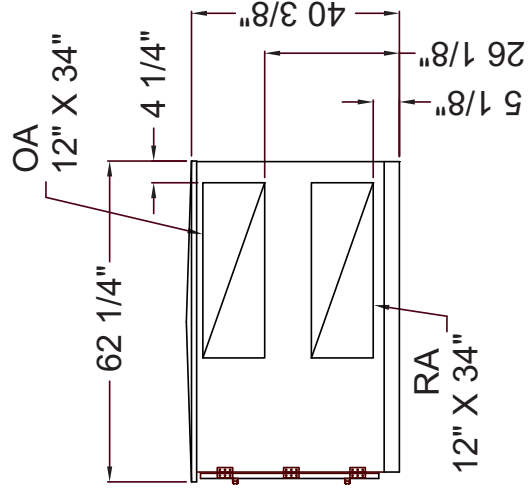

Right View

Note: There are two 12" x 12" discharges.

# HE3XINV



## Indoor Unit

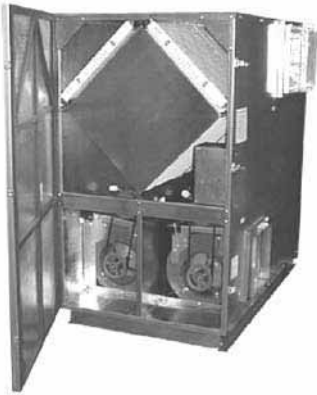

## Specifications

Ventilation Type: Static Plate, Heat and Humidity Transfer						
Typical Airflow Range: 750-3,300 CFM						
AHRI 1060 Certified Core: Three L125-00						
Airflow Rating Points (for AHRI): 2,250 CFM and 1,690 CFM						
Number Motors: Two						
HP	Volts	HZ	Phase	FLA	Min. Cir. Amps	Max. Fuse Size
2	208-230	60	Single	11.3-10.5	25.4	35
	208-230	60	Three	6.2-6.2	14.0	20
	460	60	Three	3.1	7.0	15
	575	60	Three	2.3	5.2	15
3	208-230	60	Single	13.7	30.8	45
	208-230	60	Three	9.2-8.6	20.7	30
	460	60	Three	4.3	9.7	15
	575	60	Three	3.2	7.2	15
5	208-230	60	Three	14.0-13.0	31.5	45
	460	60	Three	6.5	14.6	20
	575	60	Three	5.0	11.3	15
	Control Voltage: 24 VAC					
Filters: Six total, MERV 8, 2" pleated, 20" x 20" nominal size						
Weight: 640 lbs (unit), 675 lbs (shipping weight)						
Shipping Dimensions: 45" W x 70" L x 70" H						

## G5 Performance

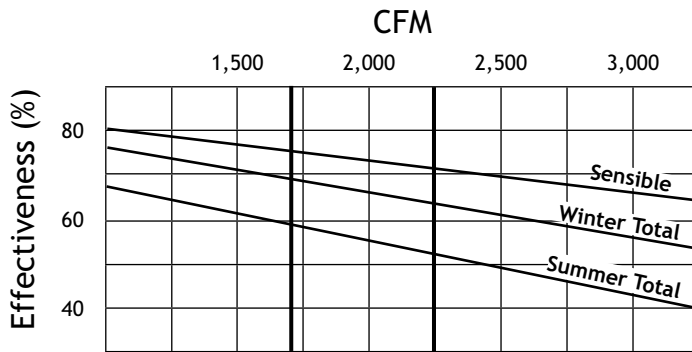

\*At AHRI 1060 standard conditions  
(See certified data on page 67 for core components.)

## Airflow Performance

Motor HP	Blower RPM Nominal	Turns Open	External Static Pressure (Inches Water Column)													
			0.0		0.25		0.5		0.75		1.0		1.25		1.5	
			CFM	BHP	CFM	BHP	CFM	BHP	CFM	BHP	CFM	BHP	CFM	BHP	CFM	BHP
2	1,095	4	1,900	1.3	1,600	1.2	1,250	1.2	850	1.1	-	-	-	-	-	-
	1,220	2	2,200	1.5	1,960	1.4	1,610	1.3	1,240	1.3	860	1.2	-	-	-	-
	1,340	0	2,300	1.7	2,160	1.6	1,950	1.5	1,580	1.4	1,150	1.3	800	1.2	-	-
3	1,345	4.5	2,400	2.2	2,250	2.2	1,970	2.1	1,570	2.0	1,170	1.9	900	1.8	-	-
	1,535	2	2,720	2.7	2,450	2.5	2,250	2.4	1,950	2.3	1,650	2.2	1,200	2.0	875	1.9
	1,685	0	-	-	2,870	3.0	2,740	2.9	2,540	2.8	2,340	2.7	2,090	2.5	1,800	2.4
5	1,495	6.5	2,850	2.7	2,610	2.6	2,380	2.5	2,090	2.4	1,710	2.2	1,330	2.1	950	2.0
	1,675	3.5	3,230	3.7	3,090	3.5	2,850	3.3	2,610	3.1	2,380	2.9	2,090	2.7	1,810	2.5
	1,855	0	3,520	4.5	3,370	4.3	3,230	4.1	3,090	3.9	2,850	3.6	2,610	3.4	2,380	3.2

# HE3XIN V UNIT DIMENSIONS

EA: Exhaust Air to outdoors  
 OA: Outdoor Air Intake  
 RA: Room Air to be exhausted  
 FA: Fresh Air to inside

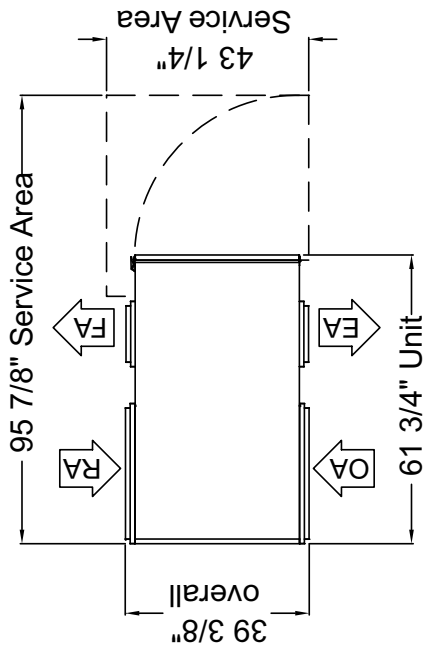

Top View

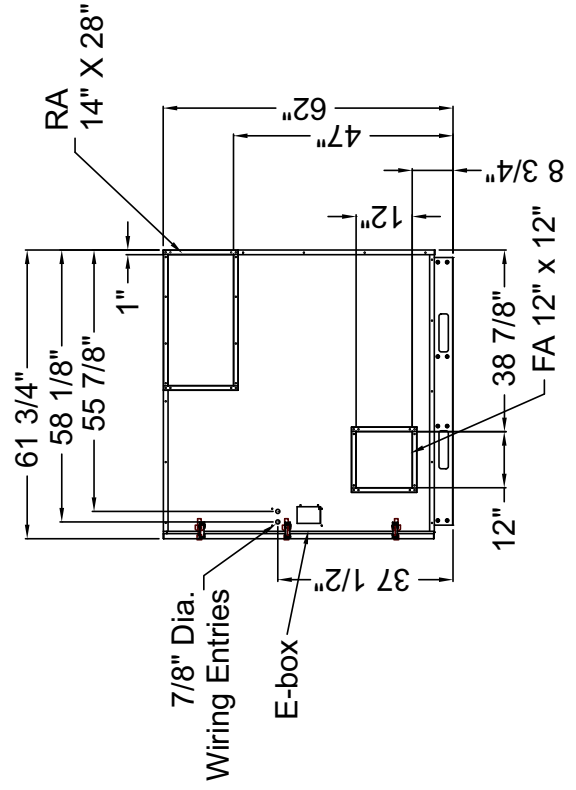

Front View

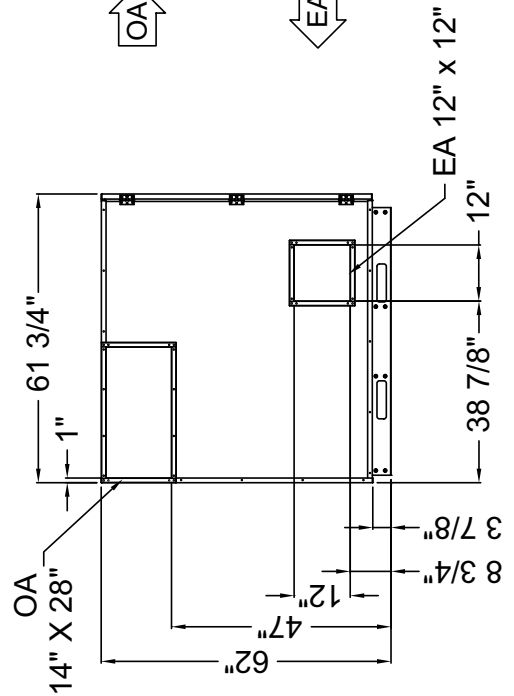

Left View

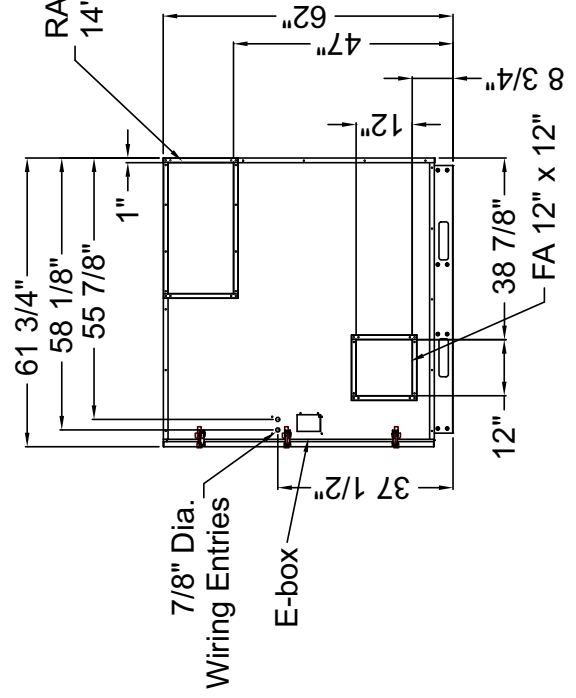

Right View

# HE4XINH



## Indoor Unit

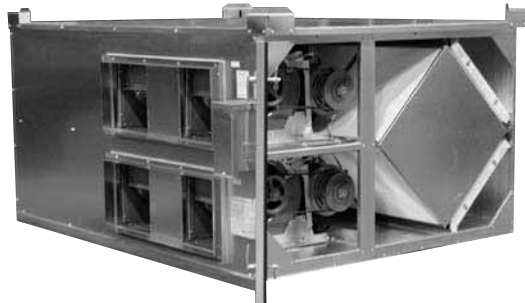

## Specifications

Ventilation Type: Static Plate, Heat and Humidity Transfer						
Typical Airflow Range: 1,000-4,400 CFM						
AHRI 1060 Certified Core: Four L125-00						
Airflow Rating Points (for AHRI): 3,000 CFM and 2,250 CFM						
Number Motors: Two						
HP	Volts	HZ	Phase	FLA	Min. Cir. Amps	Max. Fuse Size
2	208-230	60	Single	11.3-10.5	25.4	35
	208-230	60	Three	6.2-6.2	14.0	20
	460	60	Three	3.5	7.9	15
	575	60	Three	2.3	5.2	15
3	208-230	60	Single	13.7	30.8	45
	208-230	60	Three	9.2-8.6	20.7	30
	460	60	Three	4.3	9.7	15
	575	60	Three	3.2	7.2	15
5	208-230	60	Three	14.0-13.0	31.5	45
	460	60	Three	6.5	14.6	20
	575	60	Three	5.0	11.3	15
	Control Voltage: 24 VAC					
Filters: Eight total, MERV 8, 2" pleated, 20" x 20" nominal size						
Weight: 846 lbs (unit), 900 lbs (shipping weight)						
Shipping Dimensions: 84" W x 92" L x 46" H						

## G5 Performance

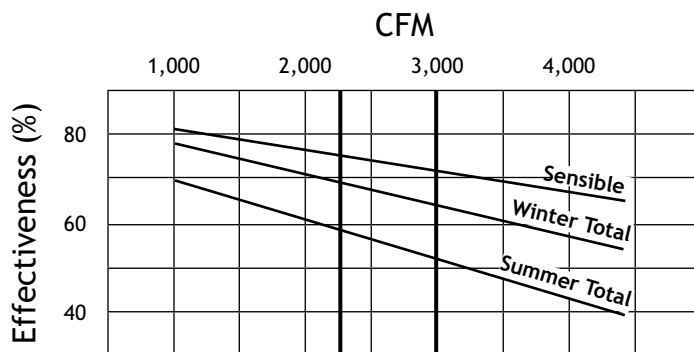

\*At AHRI 1060 standard conditions  
(See certified data on page 67 for core components.)

## Airflow Performance

Motor HP	Blower RPM Nominal	Turns Open	External Static Pressure (Inches Water Column)													
			0.0		0.25		0.5		0.75		1.0		1.25		1.5	
			CFM	BHP	CFM	BHP	CFM	BHP	CFM	BHP	CFM	BHP	CFM	BHP	CFM	BHP
2	1,010	4.5	2,489	0.9	2,200	0.9	1,715	0.8	1,100	0.7	-	-	-	-	-	-
	1,210	2	2,995	1.6	2,290	1.5	2,430	1.4	2,005	1.3	1,540	1.2	-	-	-	-
	1,370	0	-	-	-	-	-	-	2,600	2.0	2,215	1.9	1,800	1.7	1,100	1.5
3	1,345	4.5	3,295	2.1	3,145	2.1	2,840	2.0	2,509	1.9	2,116	1.8	1,747	1.6	1,135	1.5
	1,535	2	3,832	2.9	3,682	2.9	3,480	2.8	3,170	2.6	2,839	2.4	2,449	2.3	1,878	2.0
	1,685	0	-	-	-	-	-	-	-	-	3,409	3.0	3,003	2.8	2,465	2.4
5	1,495	6	3,718	2.7	3,568	2.6	3,345	2.6	3,030	2.4	2,686	2.2	2,301	2.1	1,722	1.9
	1,675	3	4,223	3.8	4,083	3.7	3,943	3.6	3,659	3.4	3,364	3.2	2,994	2.9	2,490	2.7
	1,855	0	-	-	-	-	-	-	4,287	4.9	4,011	4.6	3,760	4.3	3,434	4.0

# HE4XINH UNIT DIMENSIONS

- EA: Exhaust Air to outdoors
- OA: Outdoor Air Intake
- RA: Room Air to be exhausted
- FA: Fresh Air to inside

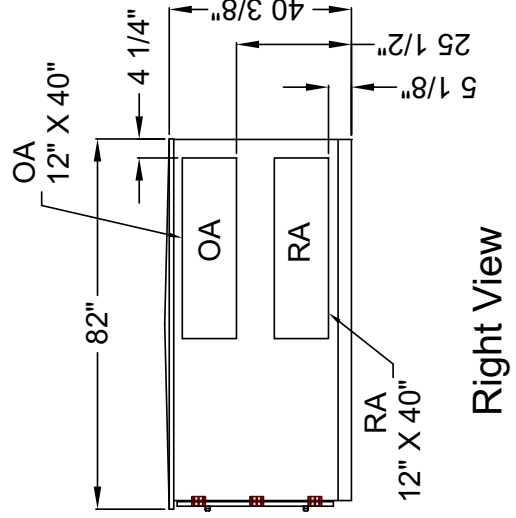
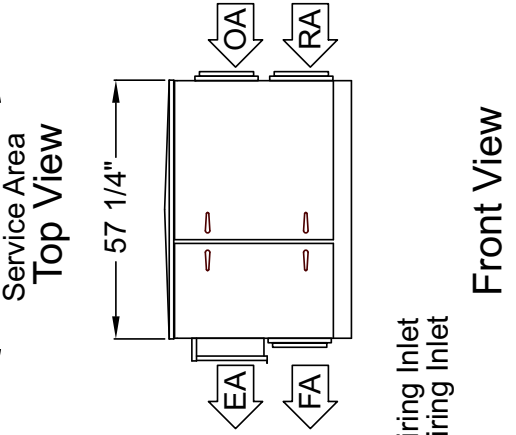
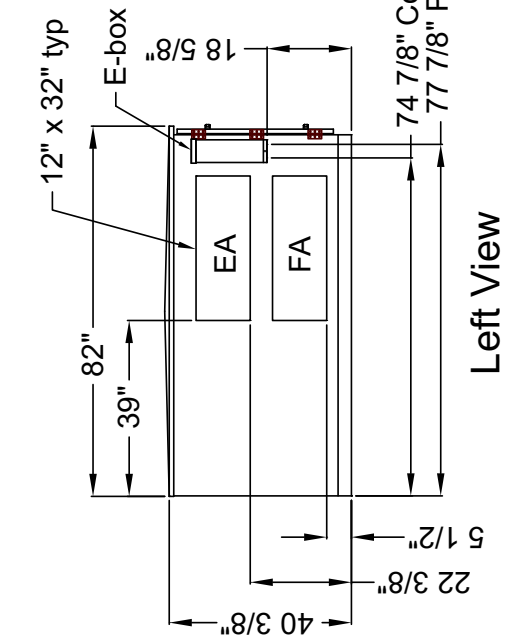
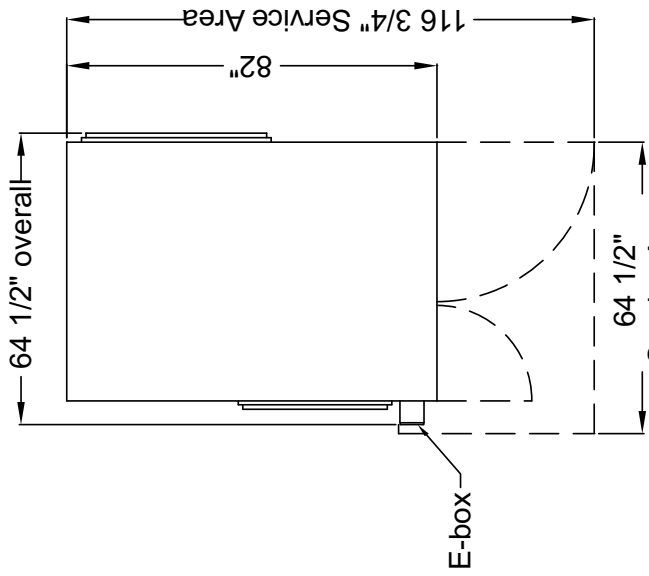

# HE4XINV



## Indoor Unit

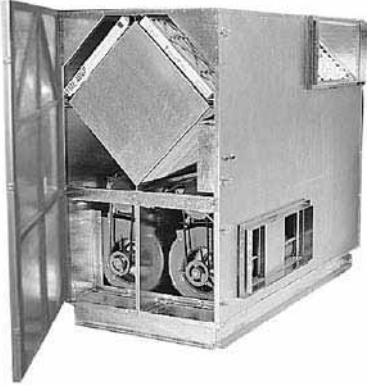

## Specifications

Ventilation Type: Static Plate, Heat and Humidity Transfer						
Typical Airflow Range: 1,000-4,400 CFM						
AHRI 1060 Certified Core: Four L125-00						
Airflow Rating Points (for AHRI): 3,000 CFM and 2,250 CFM						
Number Motors: Two						
HP	Volts	HZ	Phase	FLA	Min. Cir. Amps	Max. Fuse Size
2	208-230	60	Single	11.3-10.5	25.4	35
	208-230	60	Three	6.2-6.2	14.0	20
	460	60	Three	3.5	7.9	15
	575	60	Three	2.3	5.2	15
3	208-230	60	Single	13.7	30.8	45
	208-230	60	Three	9.2-8.6	20.7	30
	460	60	Three	4.3	9.7	15
	575	60	Three	3.2	7.2	15
5	208-230	60	Three	14.0-13.0	31.5	45
	460	60	Three	6.5	14.6	20
	575	60	Three	5.0	11.3	15
	Control Voltage: 24 VAC					
Filters: Eight total, MERV 8, 2" pleated, 20" x 20" nominal size						
Weight: 815 lbs (unit), 875 lbs (shipping weight)						
Shipping Dimensions: 45" W x 90" L x 70" H						

## G5 Performance

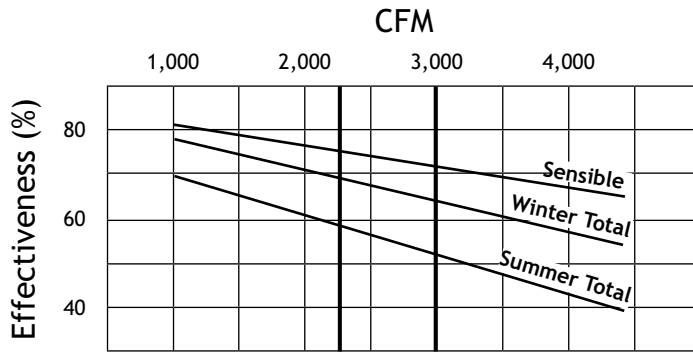

\*At AHRI 1060 standard conditions  
(See certified data on page 67 for core components.)

## Airflow Performance

Motor HP	Blower RPM Nominal	Turns Open	External Static Pressure (Inches Water Column)													
			0.0		0.25		0.5		0.75		1.0		1.25		1.5	
			CFM	BHP	CFM	BHP	CFM	BHP	CFM	BHP	CFM	BHP	CFM	BHP	CFM	BHP
2	1,010	4.5	2,300	0.9	1,810	0.8	1,300	0.7	-	-	-	-	-	-	-	-
	1,210	2	2,800	1.5	2,350	1.4	1,950	1.3	1,500	1.3	1,050	1.2	-	-	-	-
	1,370	0	3,068	2.2	2,754	2.0	2,430	1.9	2,082	1.8	1,725	1.7	1,342	1.6	-	-
3	1,345	4.5	3,042	2.0	2,705	1.9	2,341	1.8	1,983	1.7	1,611	1.6	1,211	1.5	-	-
	1,535	2	3,452	2.7	3,226	2.6	2,955	2.5	2,696	2.3	2,422	2.2	2,093	2.0	1,722	1.9
	1,685	0	-	-	-	-	-	-	3,148	2.9	2,884	2.8	2,595	2.6	2,269	2.4
5	1,495	6	3,348	2.7	3,114	2.6	2,820	2.4	2,549	2.3	2,268	2.2	1,917	2.1	1,523	1.9
	1,675	3	3,896	3.9	3,688	3.7	3,466	3.6	3,232	3.4	2,972	3.2	2,694	3.0	2,392	2.8
	1,855	0	-	-	-	-	4,229	4.9	3,979	4.6	3,700	4.3	3,430	4.0	3,178	3.8



# HE6XIN



## Indoor Unit



## Specifications

Ventilation Type: Static Plate, Heat and Humidity Transfer						
Typical Airflow Range: 1,500-6,500 CFM						
AHRI 1060 Certified Core: Six L125-00						
Airflow Rating Points (for AHRI): 4,500 CFM and 3,375 CFM						
Number Motors: Two						
HP	Volts	HZ	Phase	FLA	Min. Cir. Amps	Max. Fuse Size
5	208-230	60	Three	14.2-13.0	32.6	45
	460	60	Three	6.5	14.9	20
	575	60	Three	5.0	11.3	15
7.5	208-230	60	Three	20.9-19.2	47.0	70
	460	60	Three	9.6	21.6	30
	575	60	Three	7.6	17.1	25
Control Voltage: 24 VAC						
Filters: Twelve total, MERV 8, 2" pleated, 20" x 20" nominal size						
Weight: 2,340 lbs (unit), 2,640 lbs (shipping weight)						
Shipping Dimensions: 85" W x 114" L x 85" H						

## G5 Performance

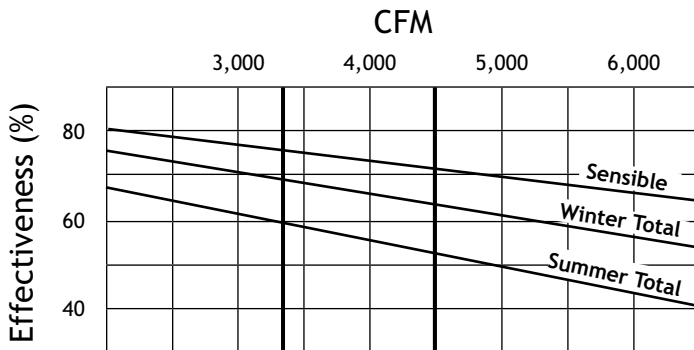

\*At AHRI 1060 standard conditions  
(See certified data on page 67 for core components.)

## Airflow Performance

Motor HP	Blower RPM Nominal	Turns Open	External Static Pressure (Inches Water Column)													
			0.0		0.25		0.5		0.75		1.0		1.25		1.5	
			CFM	BHP	CFM	BHP	CFM	BHP	CFM	BHP	CFM	BHP	CFM	BHP	CFM	BHP
5	1,460	4.5	5,005	3.2	4,800	3.2	4,650	3.1	4,475	3.0	4,200	2.9	4,000	2.8	3,750	2.8
	1,610	2	5,550	4.2	5,375	4.2	5,250	4.1	5,100	4.1	4,900	4.0	4,650	3.9	4,500	3.8
	1,725	0	-	-	-	-	-	-	5,525	5.0	5,475	5.0	5,200	4.9	5,050	4.8
7.5	1,560	4.5	5,275	3.7	5,200	3.6	4,900	3.5	4,775	3.5	4,550	3.4	4,350	3.3	4,125	3.3
	1,740	2	5,950	5.0	5,825	5.0	5,625	4.9	5,490	4.9	5,325	4.8	5,125	4.7	4,950	4.7
	1,865	0	6,500	6.5	6,350	6.5	6,225	6.4	6,125	6.4	5,910	6.3	5,825	6.2	5,625	6.1



# HE6XIN UNIT DIMENSIONS

- EA: Exhaust Air to outdoors
- OA: Outdoor Air Intake
- RA: Room Air to be exhausted
- FA: Fresh Air to inside

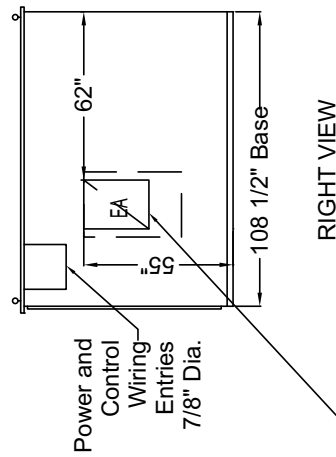
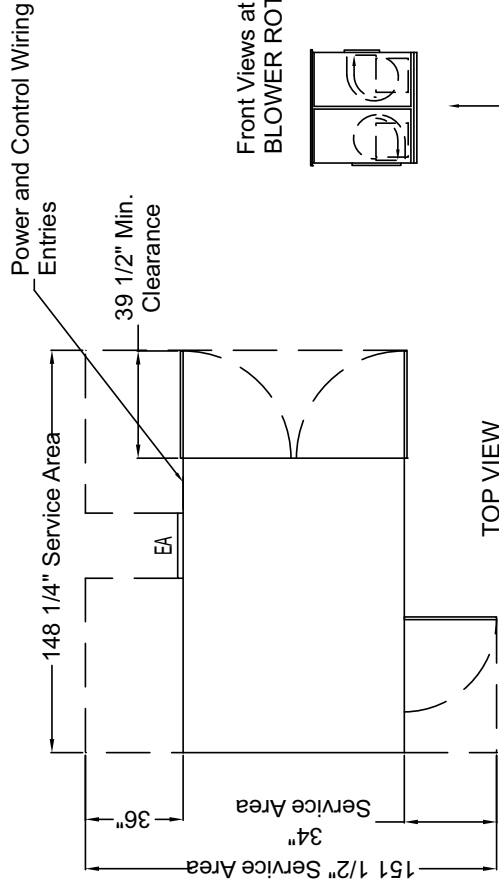

Front Views at 0.5X:  
BLOWER ROTATION



**RIGHT VIEW**

**TOP VIEW**

INDOOR UNITS: EA BLOWER Outlet is 18" x 24".  
24" x 36" Duct Flange is also supplied. Field install only in location shown.

FA BLOWER Outlet is 18" x 24".  
24" x 36" Duct Flange is also supplied.  
Field install only in location shown.

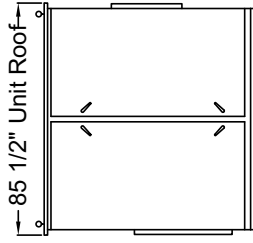
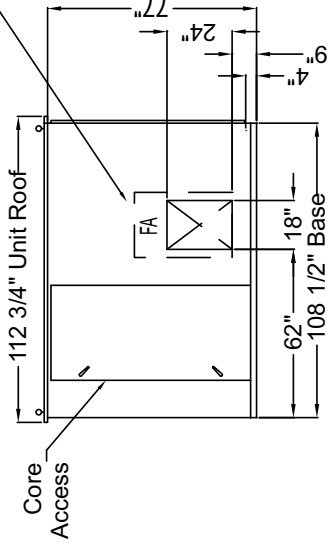
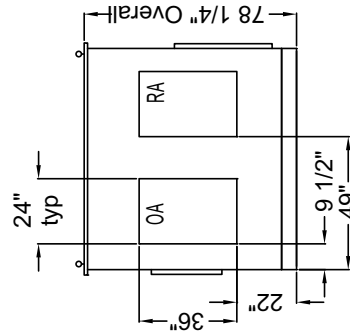

**BACK VIEW**

**LEFT VIEW**

**FRONT VIEW**

# HE8XIN



## Indoor Unit



## Specifications

Ventilation Type: Static Plate, Heat and Humidity Transfer						
Typical Airflow Range: 2,000-8,000 CFM						
AHRI 1060 Certified Core: Eight L125-00						
Airflow Rating Points (for AHRI): 6,000 CFM and 4,500 CFM						
Number Motors: Two						
HP	Volts	HZ	Phase	FLA	Min. Cir. Amps	Max. Fuse Size
5	208-230	60	Three	14.2-13.0	32.6	45
	460	60	Three	6.5	14.9	20
	575	60	Three	5.0	11.3	15
7.5	208-230	60	Three	20.9-19.2	47.0	70
	460	60	Three	9.6	21.6	30
	575	60	Three	7.6	17.1	25
10	208-230	60	Three	29.0-26.8	65.3	90
	460	60	Three	13.4	30.2	45
	575	60	Three	10.0	22.5	35
Control Voltage: 24 VAC						
Filters: Sixteen total, MERV 8, 2" pleated, 20" x 20" nominal size						
Weight: 2,525 lbs (unit), 2,825 lbs (shipping weight)						
Shipping Dimensions: 85" W x 114" L x 85" H						

## G5 Performance

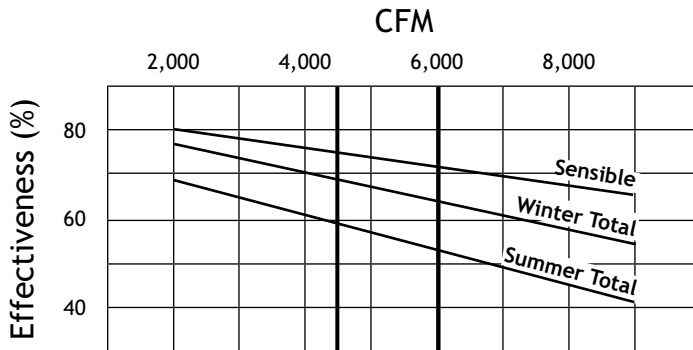

\*At AHRI 1060 standard conditions  
(See certified data on page 67 for core components.)

## Airflow Performance

Motor HP	Blower RPM Nominal	Turns Open	External Static Pressure (Inches Water Column)													
			0.0		0.25		0.5		0.75		1.0		1.25		1.5	
			CFM	BHP	CFM	BHP	CFM	BHP	CFM	BHP	CFM	BHP	CFM	BHP	CFM	BHP
5	1,460	4.5	5,575	3.2	5,425	3.2	5,200	3.2	5,000	3.2	4,775	3.1	4,550	3.0	4,270	2.9
	1,610	2	6,200	4.3	6,010	4.3	5,875	4.2	5,700	4.2	5,500	4.2	5,325	4.1	5,125	4.1
	1,725	0.5	6,550	5.0	6,380	5.0	6,210	5.0	6,100	5.0	5,880	4.9	5,730	4.8	5,510	4.8
7.5	1,560	4.5	6,000	3.9	5,850	3.9	5,650	3.8	5,475	3.8	5,275	3.8	5,100	3.7	4,875	3.7
	1,740	2	6,700	5.3	6,575	5.3	6,400	5.3	6,300	5.3	6,125	5.3	5,950	5.2	5,750	5.2
	1,865	0	-	-	-	-	-	-	6,800	7.5	6,675	7.5	6,500	7.5	6,375	7.4
10	1,810	4.5	7,000	6.1	6,875	6.1	6,750	6.1	6,600	6.0	6,425	6.0	6,275	6.0	6,100	5.9
	2,020	2	7,850	8.5	7,745	8.5	7,625	8.5	7,450	8.4	7,350	8.4	7,200	8.3	7,050	8.3
	2,105	1	-	-	-	-	7,950	9.6	7,800	9.6	7,725	9.6	7,600	9.5	7,450	9.5

# HESXIN UNIT DIMENSIONS

EA: Exhaust Air to outdoors  
 OA: Outdoor Air Intake  
 RA: Room Air to be exhausted  
 FA: Fresh Air to inside

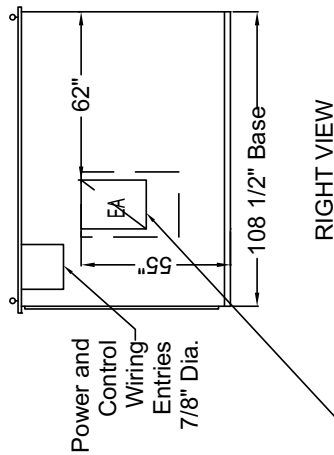
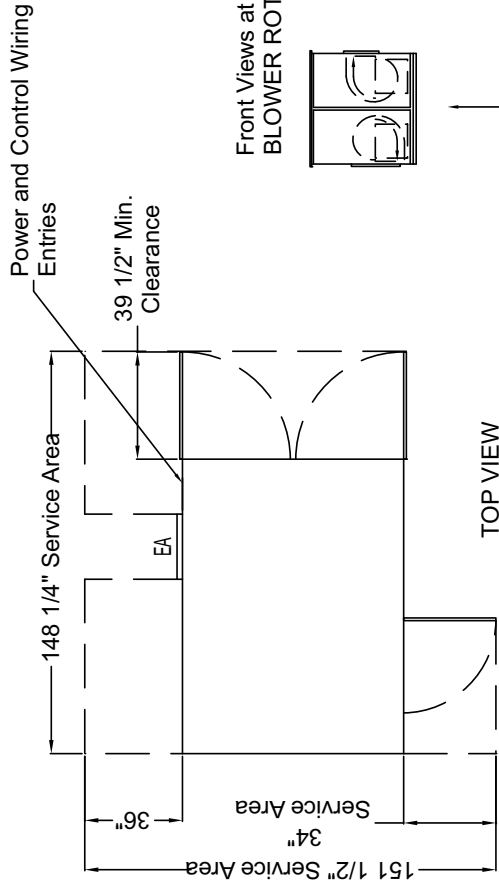

Front Views at 0.5X:  
 BLOWER ROTATION



RIGHT VIEW

TOP VIEW

FA BLOWER Outlet is 18" x 24".  
 24" x 36" Duct Flange is also supplied.  
 Field install only in location shown.

INDOOR UNITS: EA BLOWER Outlet is 18" x 24".  
 24" x 36" Duct Flange is also supplied. Field install only in location shown.

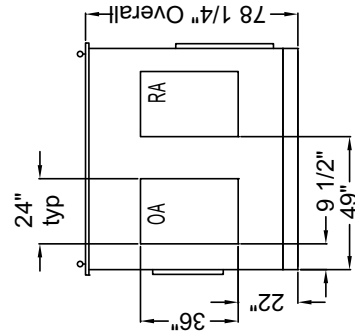

BACK VIEW

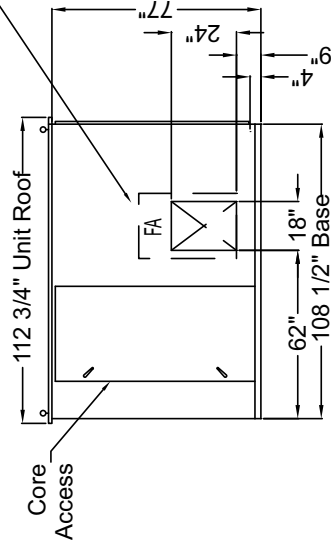

LEFT VIEW

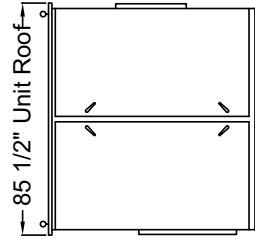

FRONT VIEW

# COMMERCIAL OUTDOOR PRODUCTS

- Many airflow orientation options.
- Weatherized cabinets with hoods for outdoor applications.
- Wide range of airflow and static capacities.
- Easy installation and service.
- AHRI certified performance data for efficiency and cross leakage.
- UL tested flammability and smoke generation that meets NFPA 90A and 90B test standards for commercial applications.
- Ten year core warranty.

## RenewAire means *Trouble-Free* ERV.

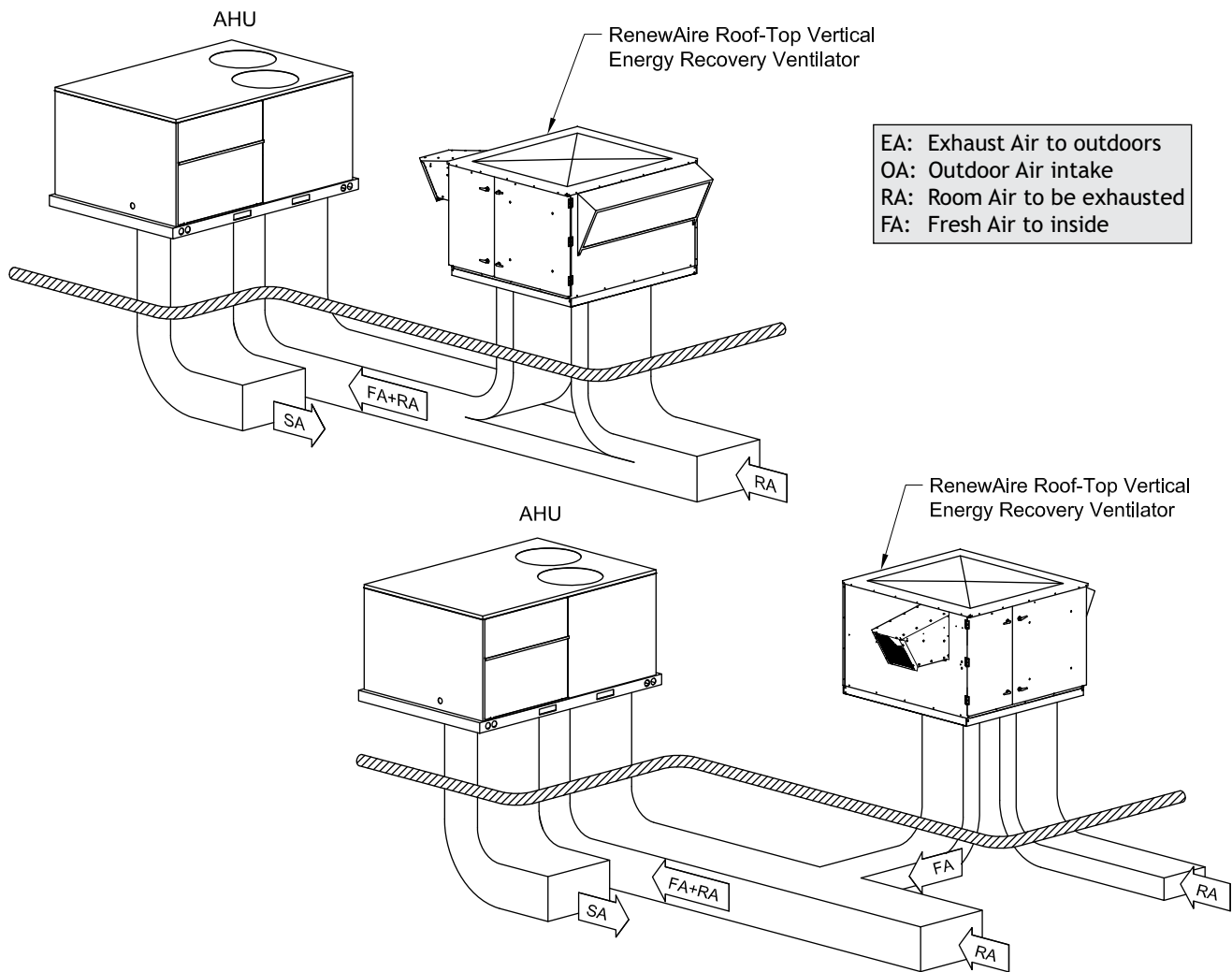

Contact RenewAire for other application schematics.

# Packaged Rooftop Energy Recovery Ventilators: EV450RT, HE1XRT, HE2XRT, HE3XRT, HE4XRT, HE6XRT & HE8XRT

## Part I - General

### A. Product Specification

1. Energy Recovery Ventilator (ERV) shall be a packaged unit as manufactured by RenewAire and shall transfer both heat and humidity using static plate core technology.

### B. Quality Assurance

1. The energy recovery cores used in these products shall be third party Certified by AHRI under its Standard 1060 for Energy Recovery Ventilators. AHRI published certifications shall confirm manufacturer's published performance for airflow, static pressure, temperature and total effectiveness, purge air (OACF) and exhaust air leakage (EATR). Products that are not currently AHRI Certified will not be accepted.

2. Manufacturer shall be able to provide evidence of independent testing of the core by Underwriters Laboratory (UL), verifying a maximum flame spread index (FSI) of 25 and a maximum smoke developed index (SDI) of 50 thereby meeting NFPA 90A and NFPA 90B requirements for materials in a compartment handling air intended for circulation through a duct system. The method of test shall be UL Standard 723.

3. Unit shall be Listed under UL 1812 Standard for Ducted Air to Air Heat Exchangers (Note that a few low volume product or product configurations are not UL Listed). Units intended for "Outdoor Use" shall be listed using the specific UL requirements for rain penetration, corrosion protection and seal durability and shall be so labeled.

4. The ERV core shall be warranted to be free of manufacturing defects and to retain its functional characteristics, under circumstances of normal use, for a period of ten years from the date of purchase. The balance-of-unit shall be warranted to be free of manufacturing defects and to retain its functional characteristics, under circumstances of normal use, for a period of two years from the date of purchase.

## Part II - Performance

### A. Energy Transfer

The ERV shall be capable of transferring both sensible and latent energy between airstreams. Latent energy transfer shall be accomplished by direct water vapor transfer from one airstream to the other, without exposing transfer media in succeeding cycles directly to the exhaust air and then to the fresh air.

### B. Passive Frost Control

The ERV core shall perform without condensing or frosting under normal operating conditions (defined as outside temperatures above -10°F and inside relative humidity below 40%). Occasional more extreme conditions shall not affect the usual function, performance or durability of the core. No condensate drains will be allowed.

### C. Continuous Ventilation

Unit shall have the capacity to operate continuously without the need for bypass, recirculation, pre-heaters or defrost cycles under normal operating conditions.

### D. Positive Airstream Separation

Water vapor transfer shall be through molecular transport by hydroscopic resin and shall not be accomplished by "porous plate" mechanisms. Exhaust and fresh airstreams shall travel at all times in separate passages, and airstreams shall not mix.

### E. Laminar Flow

Airflow through the ERV core shall be laminar over the products entire operating airflow range, avoiding deposition of particulates on the interior of the energy exchange plate material.

## Part III - Product

### A. Construction

1. The energy recovery component shall be of fixed-plate cross-flow construction, with no moving parts.

2. No condensate drain pans or drains shall be allowed and unit shall be capable of operating in both winter and summer conditions without generating condensate.

3. The unit case shall be constructed of G90 galvanized, 20-gauge steel, with lapped corners and zinc plated screw fasteners. The unit roof shall be one piece or have watertight standing seam joints and shall overlap wall panels and doors in order to positively shed water.

4. Access doors shall provide easy access to blowers, ERV cores and filters. Doors shall have an airtight compression seal using closed cell foam gaskets rated for outdoor exposure.

5. Weatherhoods shall be screened to exclude birds and animals. Inlet weatherhoods shall be sized to maintain inlet velocities below 500 fpm, and equipped with rain excluder baffles.

6. Case walls and doors shall be insulated with 1 inch, 4 pound density, foil/ scrim faced, high-density fiberglass board insulation, providing a cleanable surface and eliminating the possibility of exposing the fresh air to glass fibers.

7. The ERV cores shall be protected by a MERV-8 rated, 2" nominal, pleated, disposable filter in both airstreams.

8. Unit shall have single-point power connection and a single-point 24 VAC contactor control connection (Except Inverter Ready units that have terminal connections for an independent inverter for each airstream).

9. Blower motors shall be EPACT compliant for energy efficiency and be thermally protected or supplied with external starters.

10. Blowers shall be quiet running, forward curve type and be either direct drive or belt drive. HE6X and HE8X units use backward incline, belt drive blower packages. Belt drive motors shall be provided with adjustable pulleys and motor mounts allowing for proper belt tensioning.

### B. Options *(Select options based on application requirements)*

1. Provide unit and duct connection orientation per project schedule.

2. Provide double wall construction with 24-gauge galvanized steel liner.

3. Units are available single or three phase at a full range of operating voltages. See project schedule.

4. Provide motor horsepower as specified in project schedule.

5. Provide "inverter-ready" units which include shielded power wiring and terminal connections for inverters (inverters provided and installed by others).

6. Provide factory installed fused disconnects.

7. Provide factory installed non-fused disconnects.

8. Provide factory installed transformer/relay package to supply a 24VAC power source.

9. Provide factory installed filter monitors for each airstream.

10. Provide 14 inch high, non-pitched roof curbs as available from the factory. Pitched curbs, vibration curbs, seismic curbs and other custom curbs are available directly from curb manufacturer.

11. RTC (RoofTop Connect) units shall have return air and fresh air ducts configured to permit direct tie-in to rooftop air handlers using factory offered transition piece. (See separate specification for factory transition availability.)

12. Provide high wind tie-down kit.

# EV450RT



## Outdoor Unit



## Specifications

Ventilation Type: Static Plate, Heat and Humidity Transfer			
Typical Airflow Range: 240-550 CFM			
AHRI 1060 Certified Core: One L85			
Airflow Rating Points (for AHRI): 450 CFM and 338 CFM			
Motors: One, 0.6 hp (Single Phase) One, 0.5 hp (Three Phase)			
V	HZ	Phase	FLA
115	60	Single	7.0
208-230	60	Single	3.5
277	60	Single	2.4
208-230	60	Three	1.7-1.5
460	60	Three	0.8
Control Voltage: 24 VAC			
Filters: Two total, MERV 8, 2" pleated, 14" x 20" nominal size			
Weight: 185 lbs (unit), 235 lbs (shipping weight)			
Shipping Dimensions: 48" W x 90" L x 25" H (on pallet)			

## G5 Performance

Airflow CFM	ESP in H <sub>2</sub> O	Watts 1P	Watts 3P	Temp EFF%	Total EFF% Winter/Summer*
240	1.00	425	243	80	75/66
338	0.85	474	313	77	71/61
380	0.75	496	345	75	69/59
450	0.50	534	412	73	66/56
500	0.25	563	461	71	64/54
550	0.00	593	516	70	62/52
600	-0.25	623	572	68	60/50

\*At AHRI 1060 standard conditions  
(See certified data on page 67 for core components.)

## Dimensions

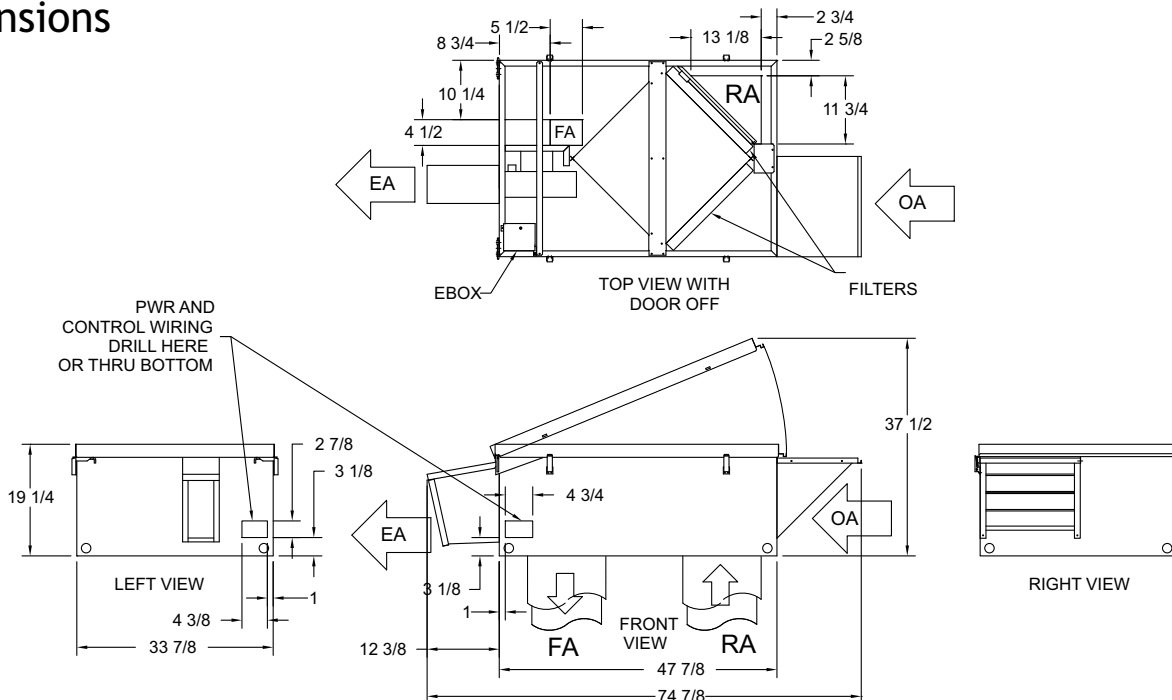

# EV450RT APPLICATION OPTIONS

### RTV

EV450RT WITH STANDARD ROOF CURB (45CURB)

TOP VIEW  
STANDARD ROOF CURB (14" HIGH)

Standard Roof Curb Shown (available option). Curbs for sloped roofs or metal roofing are available on a custom basis from RenewAire or from local curb fabricators.

Curb Cross Section (Typical for All)

---

### RTR/RTF

EV450RT WITH ADAPTER (45RTRF) AND CURB (45CURB) IN RTR CONFIGURATION

EV450RT WITH ADAPTER (45RTRF) AND CURB (45CURB) IN RTF CONFIGURATION

For horizontal connection of either the Fresh Air duct or the Return Air duct, stack the optional RTF/RTR Adapter on the Standard Roof Curb. Duct openings to be field cut into adapter. Opening location and size is flexible.

---

### RTC/RTH

EV450RT WITH ADAPTER (45RTCH)

The RTH/RTC Adapter allows horizontal connection of both the Fresh Air and the Return Air ducts. It is also possible to connect the adapter directly to the return plenum of most Rooftop Units (openings must be cut into RTU). Duct openings to be field cut into adapter. Opening location and size is flexible.

EA: Exhaust Air to outdoors  
 OA: Outdoor Air intake  
 RA: Room Air to be exhausted  
 FA: Fresh Air to inside

Think Greener. Breathe Better.

www.RenewAire.com

37

# HE1XRT



## Outdoor Unit

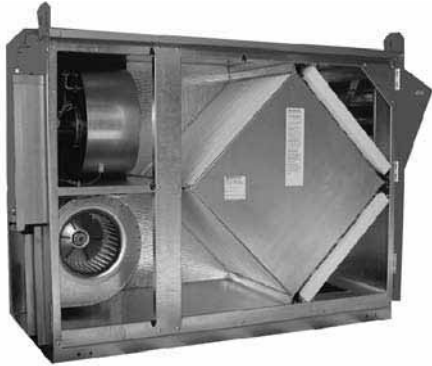

## Specifications

Ventilation Type: Static Plate, Heat and Humidity Transfer					
Typical Airflow Range: 250-870 CFM					
AHRI 1060 Certified Core: One L125-00					
Airflow Rating Points (for AHRI): 750 CFM and 560 CFM					
Number Motors: Two					
V	HZ	Phase	FLA	Min. Cir. Amps	Max. Fuse Size
115	60	Single	8.6	19.4	25
208-230	60	Single	4.3	9.7	15
277	60	Single	2.4	5.4	15
208-230	60	Three	2.1	5.2	15
460	60	Three	1.1	2.6	15
Control Voltage: 24 VAC					
Filters: Two total, MERV 8, 2" pleated, 20" x 20" nominal size					
Weight: 250 lbs (unit), 330 lbs (shipping weight)					
Shipping Dimensions: 31" W x 76" L x 45" H					
Options: Controls (see pages 64 & 65) Roof curb Alternate duct connections					

## G5 Performance

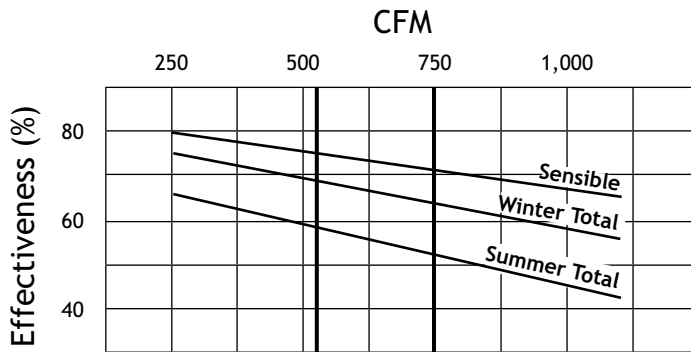

\*At AHRI 1060 standard conditions  
(See certified data on page 67 for core components.)

## Base Type/Airflow Orientations

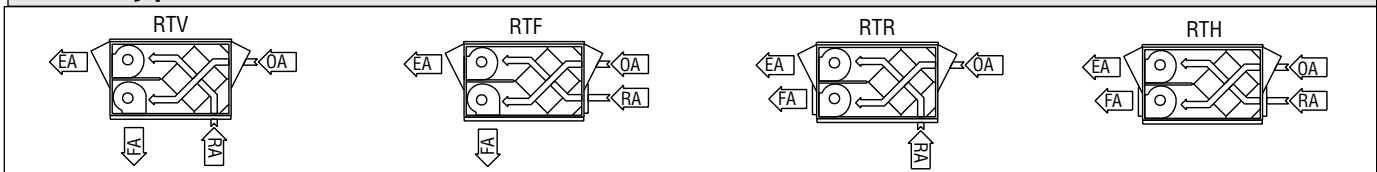

## Airflow Performance

Motor HP Phase	External Static Pressure (Inches Water Column)						
	0.0	0.25	0.5	0.75	1.0	1.25	1.5
0.75 (Two DD) Single Phase	950 CFM 1,630 Watts	880 CFM 1,550 Watts	820 CFM 1,475 Watts	775 CFM 1,430 Watts	730 CFM 1,385 Watts	650 CFM 1,300 Watts	540 CFM 1,200 Watts
0.75 (Two DD) Three Phase	950 CFM 1,200 Watts	880 CFM 1,100 Watts	820 CFM 1,020 Watts	760 CFM 980 Watts	660 CFM 890 Watts	560 CFM 800 Watts	450 CFM 700 Watts



# HEIXRT UNIT DIMENSIONS

EA: Exhaust Air to outdoors  
 OA: Outdoor Air Intake  
 RA: Room Air to be exhausted  
 FA: Fresh Air to inside

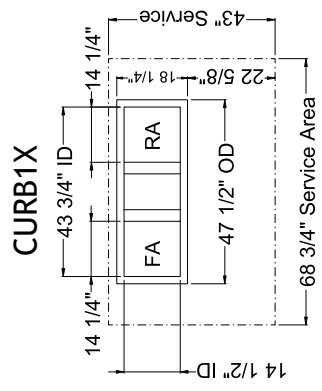
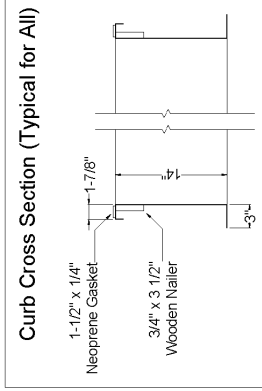
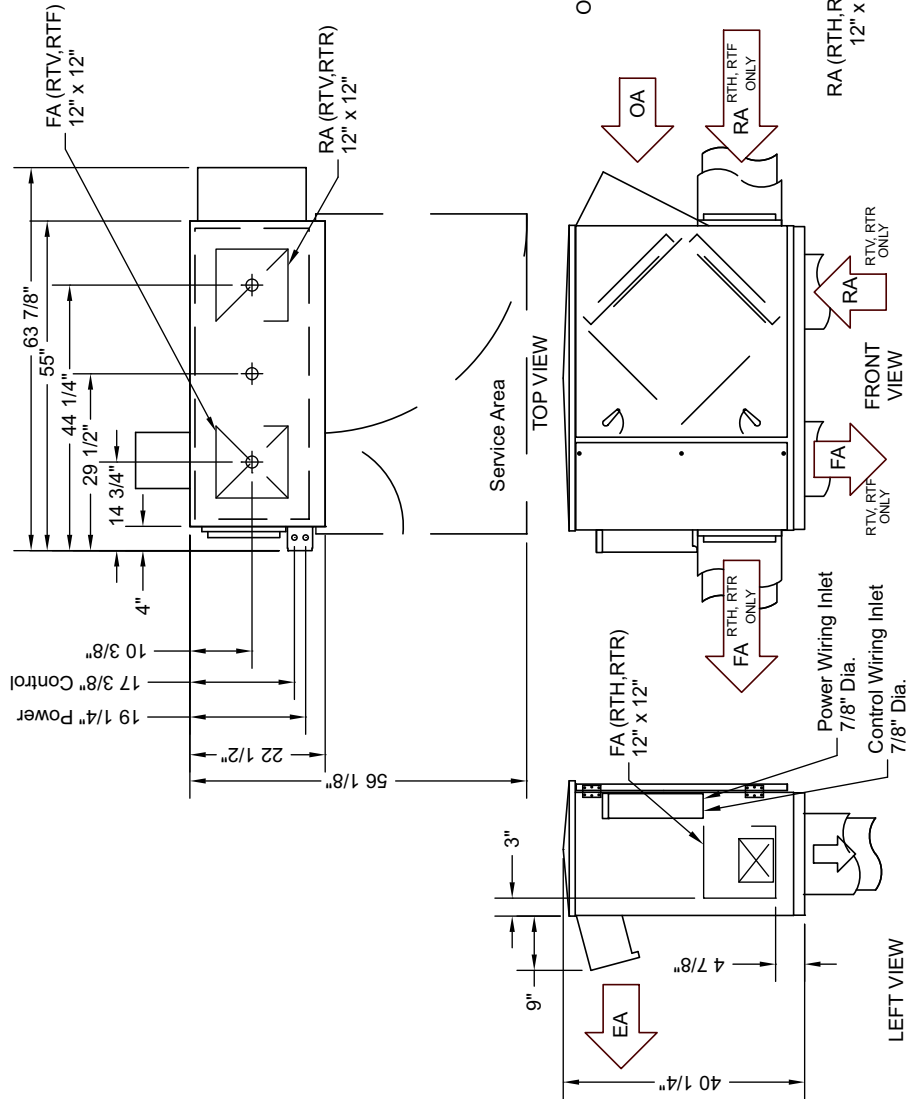

# HE1XRTC



## Outdoor Unit

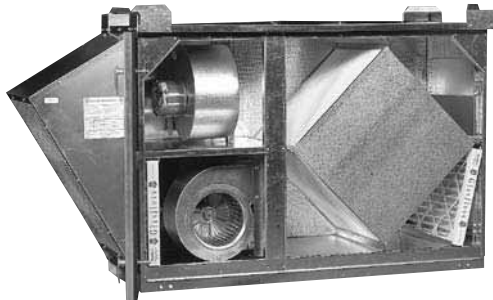

## Specifications

Ventilation Type: Static Plate, Heat and Humidity Transfer					
Typical Airflow Range: 500-1,000 CFM					
AHRI 1060 Certified Core: One L125-00					
Airflow Rating Points (for AHRI): 750 CFM and 560 CFM					
Number Motors: Two					
V	HZ	Phase	FLA	Min. Cir. Amps	Max. Fuse Size
115	60	Single	8.6	19.4	25
208-230	60	Single	4.3	9.7	15
277	60	Single	2.4	5.4	15
208-230	60	Three	2.1	5.2	15
460	60	Three	1.1	2.6	15
Control Voltage: 24 VAC					
Filters: Two total, MERV 8, 2" pleated, 20" x 20" nominal size					
Weight: 300 lbs (unit), 375 lbs (shipping weight)					
Shipping Dimensions: 40" W x 87" L x 45" H					

## G5 Performance

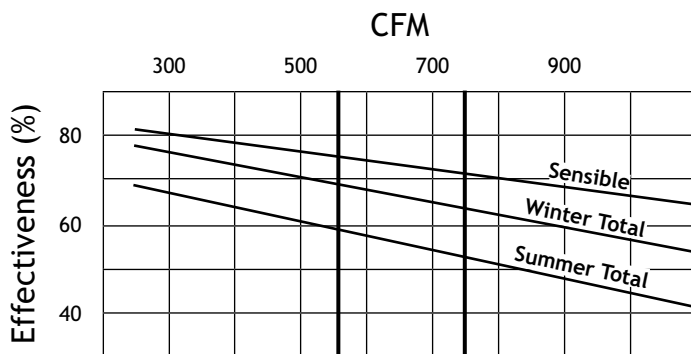

\*At AHRI 1060 standard conditions  
(See certified data on page 67 for core components).

## Airflow Performance

Damper Position	Total Watts		Static Pressure in Adjacent Air Handler (Inches Water Column)									
			-0.5		-0.25		0.0		+0.25		+0.5	
	1 Phase	3 Phase	EA	FA	EA	FA	EA	FA	EA	FA	EA	FA
100% Open	1,295	1,155	855	1,035	900	985	950	940	985	885	1,045	835
65% Open	1,285	1,140	785	980	820	945	855	900	890	855	935	810
55% Open	1,275	1,130	775	965	805	920	840	875	865	835	900	790
45% Open	1,265	1,120	750	920	775	875	805	935	830	790	860	750
35% Open	1,265	1,110	695	860	730	820	760	775	790	740	820	700
25% Open	1,265	1,100	625	780	660	750	685	715	715	680	750	650
15% Open	1,260	1,085	575	585	615	630	650	665	685	705	730	745

# HE1XRTC UNIT DIMENSIONS

EA: Exhaust Air to outdoors  
 OA: Outdoor Air Intake  
 RA: Room Air to be exhausted  
 FA: Fresh Air to inside

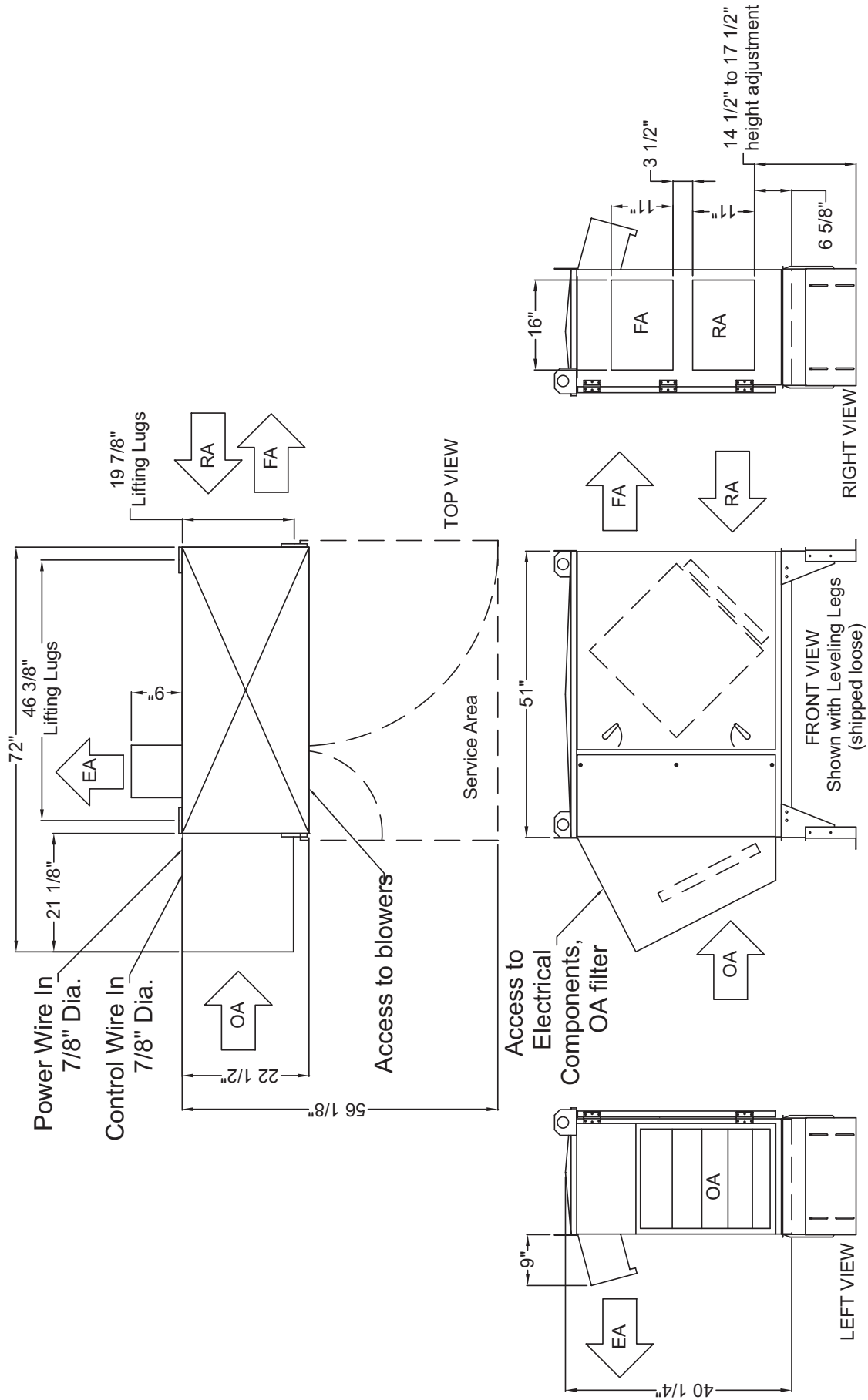

# HE2XRT



## Outdoor Unit



## Specifications

Ventilation Type: Static Plate, Heat and Humidity Transfer						
Typical Airflow Range: 500-2,000 CFM						
AHRI 1060 Certified Core: Two L125-00						
Airflow Rating Points (for AHRI): 1,500 CFM and 1,120 CFM						
Number Motors: Direct Drive (DD) Four, Belt Drive (BD) Two						
Drive HP	Volts	HZ	Phase	FLA	Min. Cir. Amps	Max. Fuse Size
DD 0.75	115	60	Single	8.6	36.6	45
	208-230	60	Single	4.3	18.3	20
	277	60	Single	2.4	10.2	15
	208-230	60	Three	2.1	9.8	15
460	60	60	Three	1.1	4.9	15
	208-230	60	Single	9.3-9.0	20.9	30
	208-230	60	Three	4.8-4.8	10.8	15
	460	60	Three	2.4	5.4	15
575	60	60	Three	1.8	4.1	15
	208-230	60	Single	11.3-10.5	25.4	35
	208-230	60	Three	6.2-6.2	14.0	20
	460	60	Three	3.1	7.0	15
575	60	60	Three	2.3	5.2	15
	Control Voltage: 24 VAC					
	Filters: Four total, MERV 8, 2" pleated, 20" x 20" nominal size					
	Weight: 488 lbs (unit), 525 lbs (shipping weight)					
Shipping Dimensions: 51" W x 76" L x 45" H						

## G5 Performance

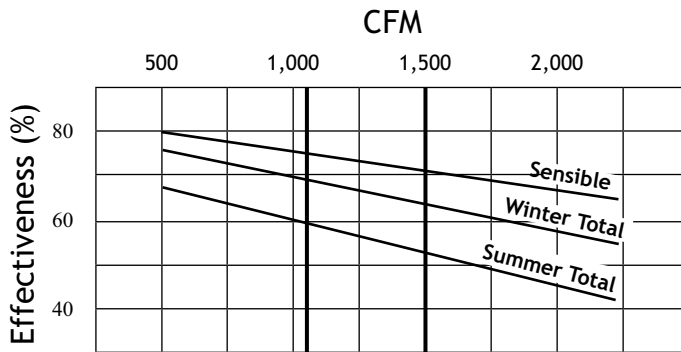

\*At AHRI 1060 standard conditions  
(See certified data on page 67 for core components).

## Base Type/Airflow Orientations

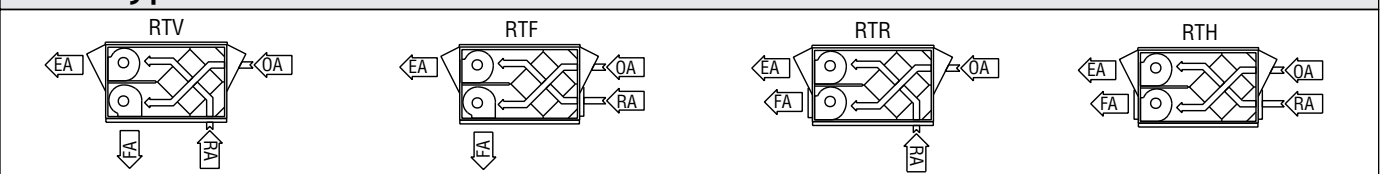

## Airflow Performance

Motor HP	Blower RPM Nominal	Turns Open	External Static Pressure (Inches Water Column)													
			0.0		0.25		0.5		0.75		1.0		1.25		1.5	
			CFM	BHP	CFM	BHP	CFM	BHP	CFM	BHP	CFM	BHP	CFM	BHP	CFM	BHP
0.75 (Four DD) Single Phase	N/A	N/A	1,770	0.5	1,680	0.5	1,555	0.4	1,375	0.4	1,110	0.4	760	0.4	-	-
	N/A	N/A	2,220	0.9	2,145	0.9	2,015	0.8	1,825	0.7	1,560	0.7	1,195	0.6	-	-
0.75 (Four DD) Three Phase	N/A	N/A	1,760	0.5	1,670	0.5	1,550	0.4	1,375	0.4	1,120	0.4	850	0.4	500	0.4
	N/A	N/A	2,300	0.9	2,200	0.9	2,050	0.8	1,825	0.7	1,530	0.7	1,375	0.6	950	0.6
1.5 (BD)	1,000	4.5	1,378	0.5	1,175	0.5	900	0.4	635	0.4	-	-	-	-	-	-
	1,230	2	1,694	0.9	1,550	0.9	1,335	0.8	1,125	0.7	1,000	0.7	500	0.6	-	-
	1,420	0	1,956	1.4	1,850	1.4	1,680	1.2	1,475	1.2	1,300	1.1	1,200	1.1	930	0.9
2 (BD)	1,220	4.5	1,681	0.9	1,530	0.9	1,315	0.7	1,100	0.7	975	0.6	430	0.6	-	-
	1,470	2	2,025	1.6	1,925	1.5	1,750	1.4	1,575	1.3	1,375	1.2	1,275	1.2	1,125	1.1
	1,660	0	-	-	-	-	2,000	2.0	1,900	1.9	1,750	1.8	1,570	1.7	1,475	1.7

Note: Brake Horse Power (BHP) is for one blower motor package only.

# HE2XRT UNIT DIMENSIONS

- EA: Exhaust Air to outdoors
- OA: Outdoor Air intake
- RA: Room Air to be exhausted
- FA: Fresh Air to inside

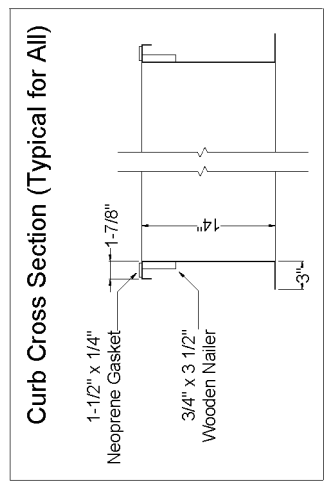
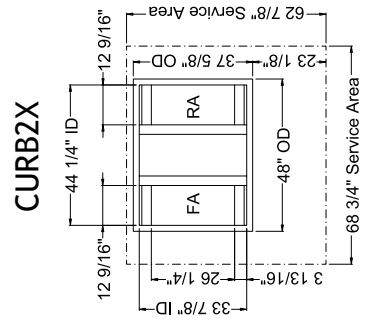
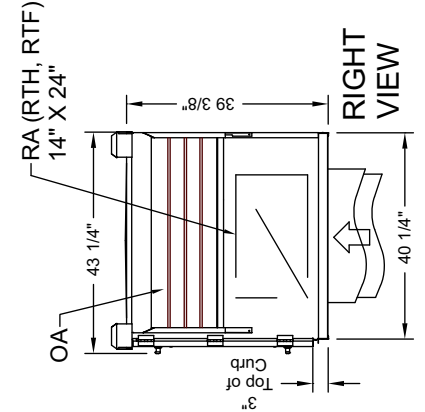
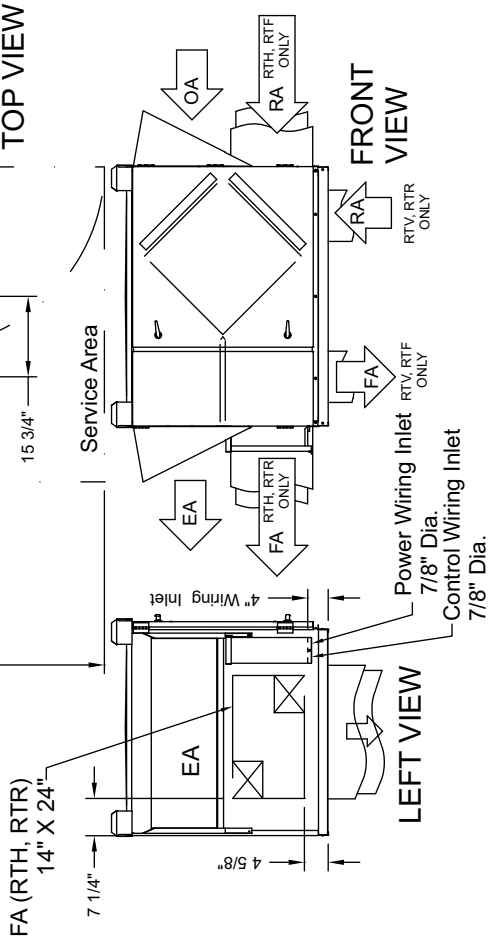
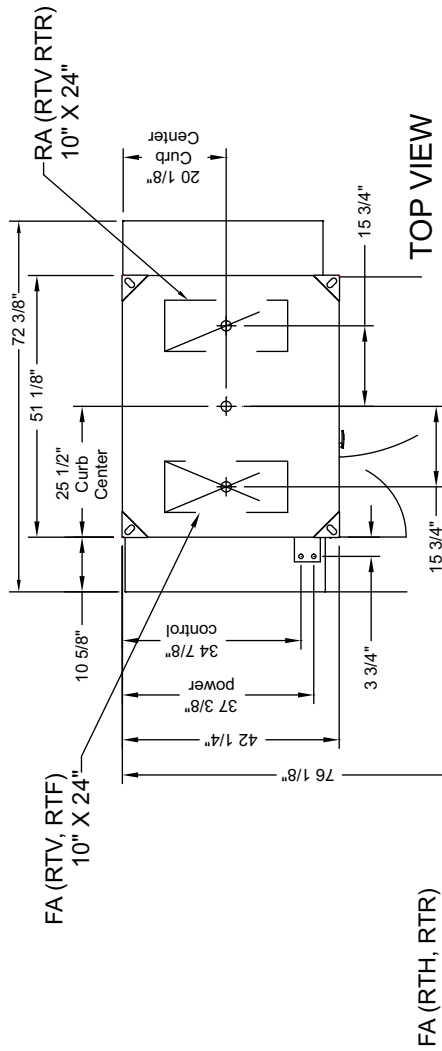

# HE2XRTC



## Outdoor Unit

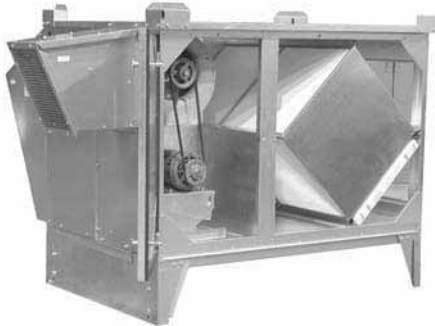

## Specifications

Ventilation Type: Static Plate, Heat and Humidity Transfer						
Typical Airflow Range: 1,000-1,700 CFM						
AHRI 1060 Certified Core: Two L125-00						
Airflow Rating Points (for AHRI): 1,500 CFM and 1,120 CFM						
Number Motors: Two, Belt Drive						
HP	Volts	HZ	Phase	FLA	Min. Cir. Amps	Max. Fuse Size
BD 2	208-230	60	Single	11.3-10.5	25.4	35
BD 2	208-230	60	Three	6.2-6.2	14.0	20
	460	60	Three	3.1	7.0	15
	575	60	Three	2.3	5.2	15
Control Voltage: 24 VAC						
Filters: Four total, MERV 8, 2" pleated, two 20" x 20" nominal size, and two 14" x 20" nominal size						
Weight: 538 lbs (unit), 575 lbs (shipping weight)						
Shipping Dimensions: 51" W x 76" L x 45" H						

## G5 Performance

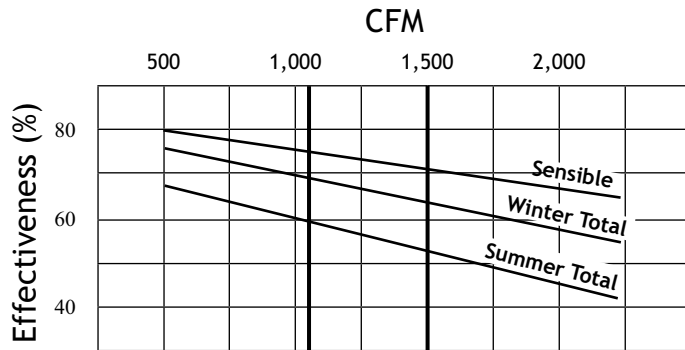

\*At AHRI 1060 standard conditions  
(See certified data on page 67 for core components).

## Airflow Performance

	Blower RPM Nominal	Turns Open	Static Pressure in Adjacent Air Handler (Inches Water Column)									
			-0.5		-0.25		0.0		+0.25		+0.5	
			CFM	BHP	CFM	BHP	CFM	BHP	CFM	BHP	CFM	BHP
Exhaust Air	1,420	0	1,700	1.8	1,850	1.9	-	-	-	-	-	-
	1,360	1	1,540	1.7	1,720	1.8	1,860	1.9	1,920	2.0	1,980	2.0
	1,300	2	1,375	1.5	1,600	1.7	1,740	1.8	1,800	1.8	1,860	1.9
	1,240	3	1,240	1.4	1,440	1.6	1,625	1.7	1,690	1.7	1,740	1.7
	1,180	4	1,080	1.3	1,300	1.4	1,500	1.5	1,575	1.6	1,640	1.6
Fresh Air	1,675	0	-	-	-	-	1,630	2.0	1,575	2.0	1,465	1.9
	1,595	1	1,720	2.0	1,620	2.0	1,530	1.9	1,440	1.8	1,355	1.7
	1,515	2	1,630	1.9	1,520	1.8	1,430	1.8	1,355	1.7	1,230	1.6
	1,435	3	1,530	1.8	1,430	1.7	1,320	1.7	1,250	1.6	1,135	1.5
	1,355	4	1,415	1.6	1,310	1.6	1,225	1.5	1,150	1.5	1,035	1.4

# HE2XRTC UNIT DIMENSIONS

EA: Exhaust Air to outdoors  
 OA: Outdoor Air Intake  
 RA: Room Air to be exhausted  
 FA: Fresh Air to inside

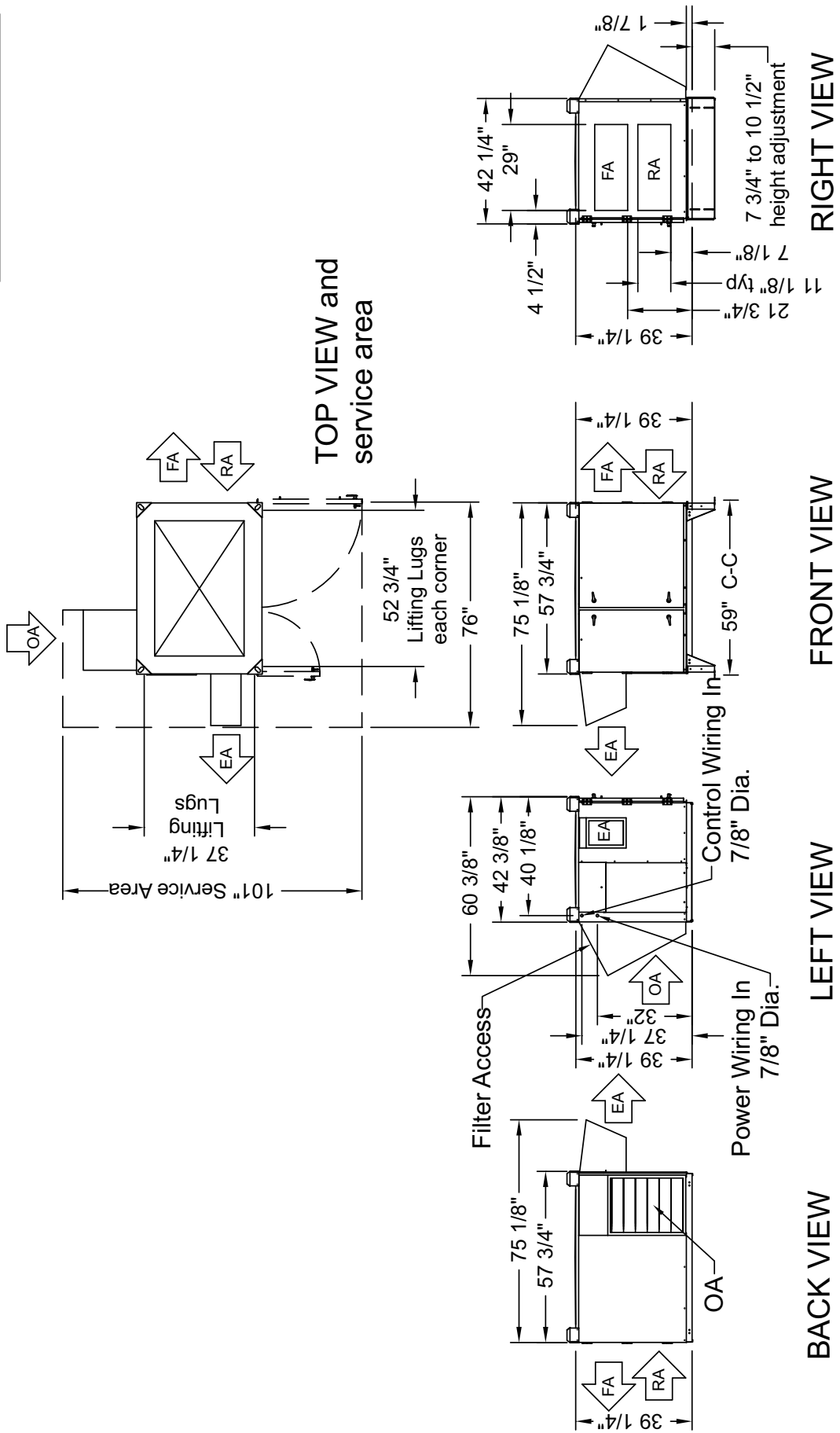

# HE3XRT



## Outdoor Unit

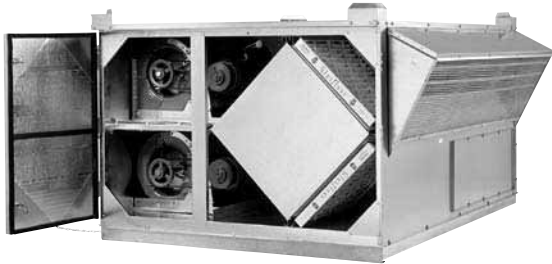

## Specifications

Ventilation Type: Static Plate, Heat and Humidity Transfer						
Typical Airflow Range: 750-3,000 CFM						
AHRI 1060 Certified Core: Three L125-00						
Airflow Rating Points (for AHRI): 2,250 CFM and 1,690 CFM						
Number Motors: Two						
HP	Volts	HZ	Phase	FLA	Min. Cir. Amps	Max. Fuse Size
2	208-230	60	Single	11.3-10.5	25.4	35
	208-230	60	Three	6.2-6.2	14.0	20
	460	60	Three	3.1	7.0	15
	575	60	Three	2.3	5.2	15
3	208-230	60	Single	13.7	30.8	45
	208-230	60	Three	9.2-8.6	20.7	30
	460	60	Three	4.3	9.7	15
	575	60	Three	3.2	7.2	15
5	208-230	60	Three	14.0-13.0	31.5	45
	460	60	Three	6.5	14.6	20
	575	60	Three	5.0	11.3	15
	Control Voltage: 24 VAC					
Filters: Six total, MERV 8, 2" pleated, 20" x 20" nominal size						
Weight: 726 lbs (unit), 755 lbs (shipping weight)						
Shipping Dimensions: 72" W x 84" L x 49" H						

## G5 Performance

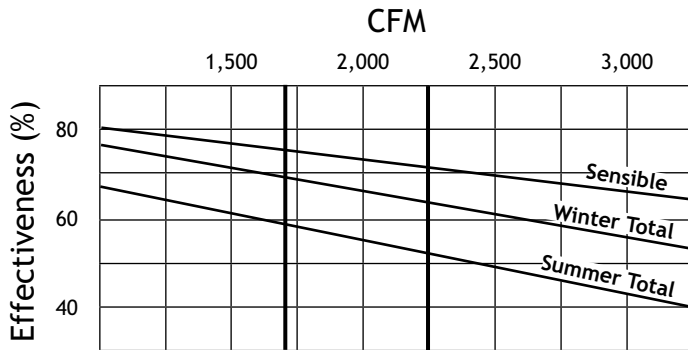

\*At AHRI 1060 standard conditions  
(See certified data on page 67 for core components).

## Base Type/Airflow Orientations

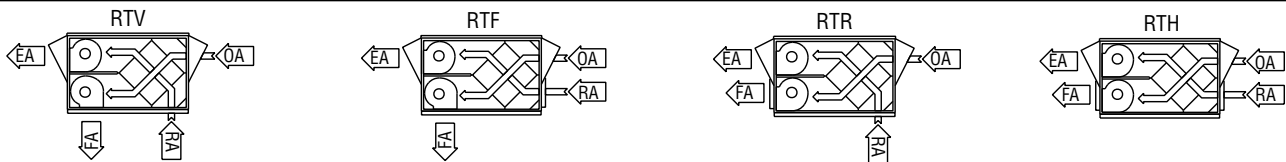

## Airflow Performance

Motor HP	Blower RPM Nominal	Turns Open	External Static Pressure (Inches Water Column)													
			0.0		0.25		0.5		0.75		1.0		1.25		1.5	
			CFM	BHP	CFM	BHP	CFM	BHP	CFM	BHP	CFM	BHP	CFM	BHP	CFM	BHP
2	1,095	4	2,040	1.3	1,760	1.3	1,370	1.2	920	1.1	-	-	-	-	-	-
	1,220	2	2,340	1.5	2,110	1.4	1,790	1.3	1,380	1.2	940	1.2	-	-	-	-
	1,340	0	2,590	1.8	2,370	1.7	2,130	1.6	1,760	1.4	1,310	1.3	980	1.2	-	-
3	1,345	4.5	2,420	2.3	2,280	2.2	2,090	2.1	1,760	2.0	1,280	1.9	860	1.9	-	-
	1,535	2	2,850	2.8	2,760	2.7	2,570	2.6	2,380	2.5	2,090	2.4	1,810	2.2	1,330	2.1
	1,685	0	-	-	-	-	-	-	2,660	2.9	2,470	2.7	2,280	2.6	2,000	2.4
5	1,495	6.5	2,850	3.1	2,710	3.0	2,520	2.9	2,280	2.8	2,040	2.7	1,620	2.5	1,140	2.4
	1,675	3.5	3,280	3.8	3,140	3.7	2,990	3.5	2,800	3.3	2,610	3.1	2,380	2.9	2,090	2.7
	1,855	0	-	-	-	-	3,470	4.9	3,330	4.7	3,140	4.5	3,040	4.4	2,760	4.0



# HE3XRT UNIT DIMENSIONS

EA: Exhaust Air to outdoors  
 OA: Outdoor Air Intake  
 RA: Room Air to be exhausted  
 FA: Fresh Air to inside

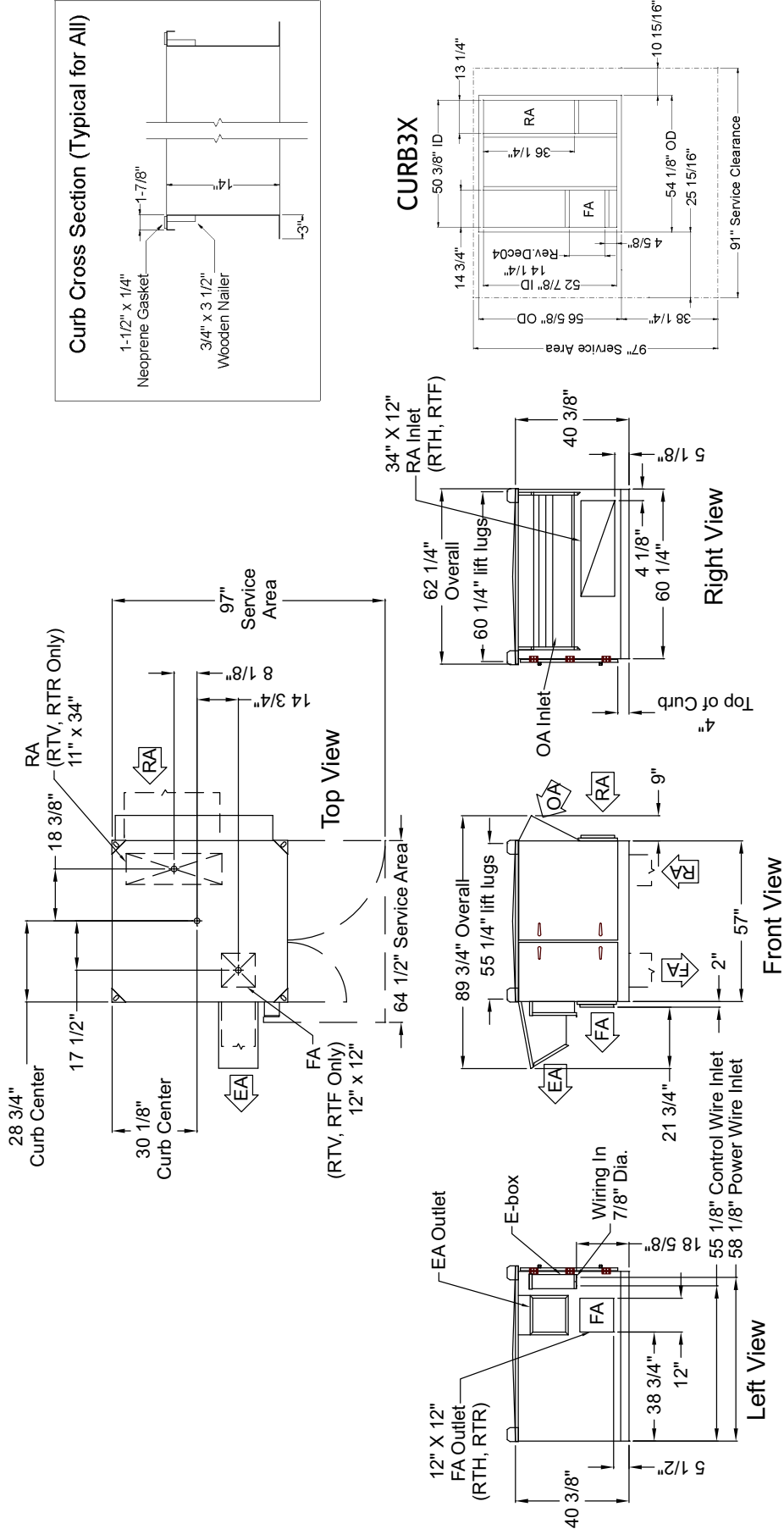

# HE3XRTC



## Outdoor Unit

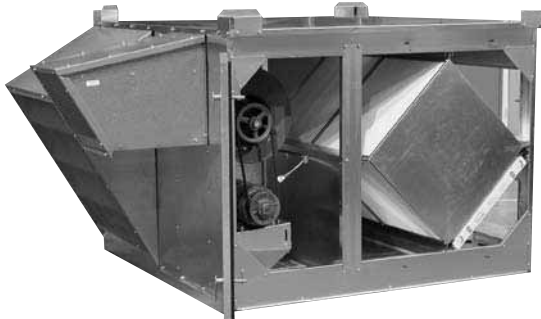

## Specifications

Ventilation Type: Static Plate, Heat and Humidity Transfer						
Typical Airflow Range: 1,700-2,500 CFM						
AHRI 1060 Certified Core: Three L125-00						
Airflow Rating Points (for AHRI): 2,250 CFM and 1,690 CFM						
Number Motors: Two						
HP	Volts	HZ	Phase	FLA	Min. Cir. Amps	Max. Fuse Size
3	208-230	60	Single	13.7-13.7	30.8	45
3	208-230	60	Three	9.2-8.6	20.7	30
	460	60	Three	4.4	9.9	15
	575	60	Three	3.2	7.2	15
Control Voltage: 24 VAC						
Filters: Five total, MERV 8, 2" pleated, three 20" x 20" and two 16" x 25" nominal size						
Weight: 775 lbs (unit), 830 lbs (shipping weight)						
Shipping Dimensions: 72" W x 84" L x 50" H						

## G5 Performance

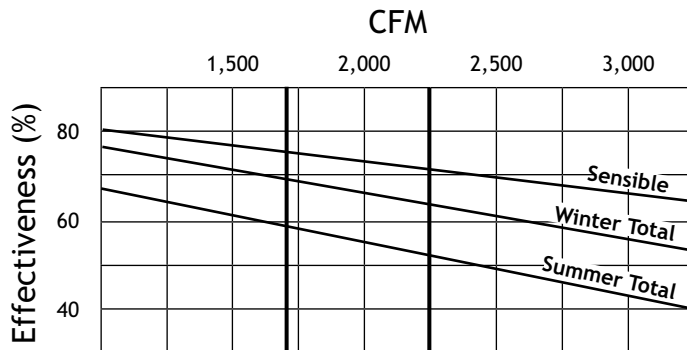

\*At AHRI 1060 standard conditions  
(See certified data on page 67 for core components).

## Airflow Performance

	Blower RPM Nominal	Turns Open	Static Pressure in Adjacent Air Handler (Inches Water Column)									
			-0.5		-0.25		0.0		+0.25		+0.5	
			CFM	BHP	CFM	BHP	CFM	BHP	CFM	BHP	CFM	BHP
Exhaust Air	1,520	0	-	-	-	-	-	-	-	-	-	-
	1,465	1	2,130	2.9	-	-	-	-	-	-	-	-
	1,405	2	2,000	2.5	2,245	2.8	2,455	3.0	-	-	-	-
	1,345	3	1,915	2.3	2,135	2.6	2,345	2.7	2,475	2.8	2,575	2.9
	1,285	4	1,725	1.8	1,950	2.1	2,180	2.3	2,345	2.4	2,455	2.5
Fresh Air	1,800	0	2,565	3.0	2,385	2.9	2,225	2.8	2,065	2.7	1,830	2.4
	1,740	1	2,480	2.8	2,290	2.7	2,150	2.6	1,975	2.5	1,740	2.2
	1,680	2	2,375	2.6	2,210	2.5	2,070	2.4	1,910	2.3	1,645	2.0
	1,620	3	2,290	2.4	2,125	2.4	1,990	2.3	1,825	2.1	1,555	1.8
	1,560	4	2,200	2.1	2,040	2.1	1,910	2.0	1,725	1.9	1,450	1.5

# HE3XRTC UNIT DIMENSIONS

EA: Exhaust Air to outdoors  
 OA: Outdoor Air Intake  
 RA: Room Air to be exhausted  
 FA: Fresh Air to inside

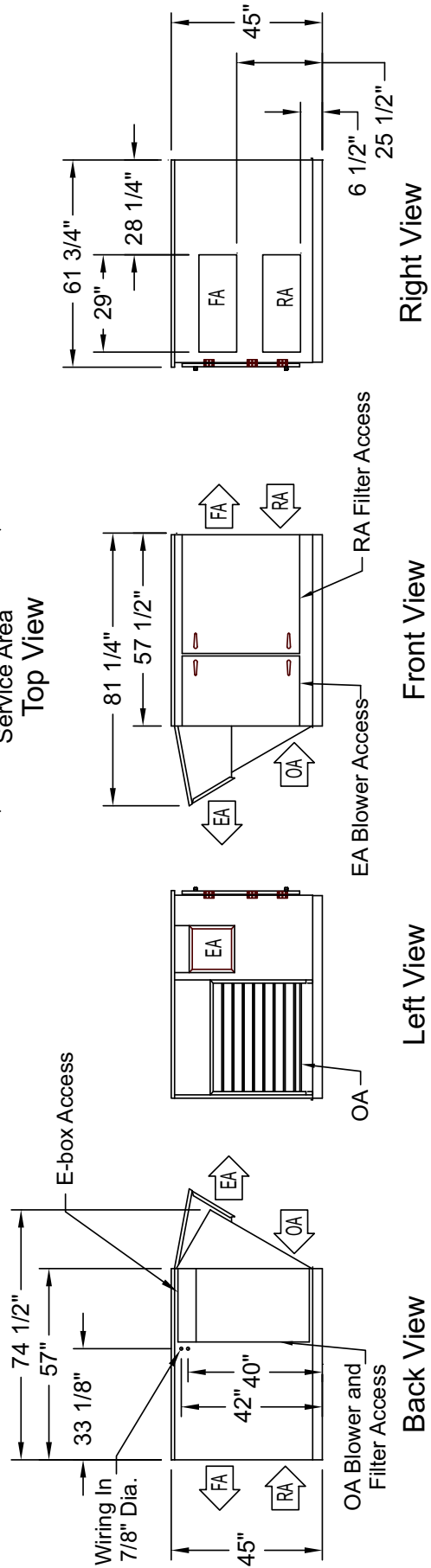
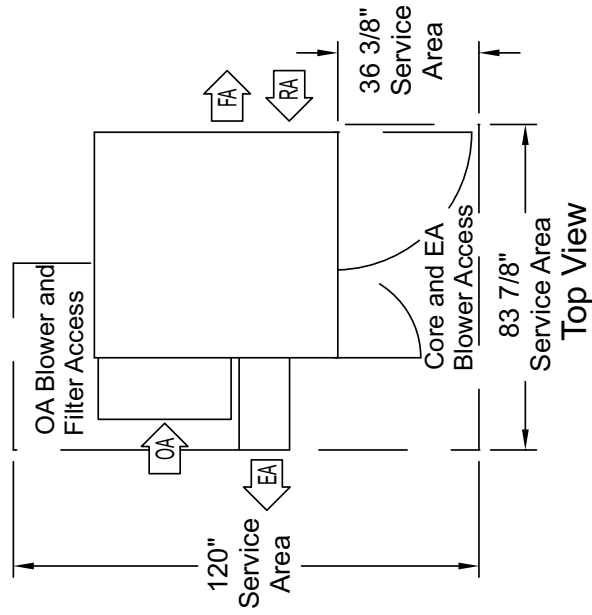

# HE4XRT



## Outdoor Unit

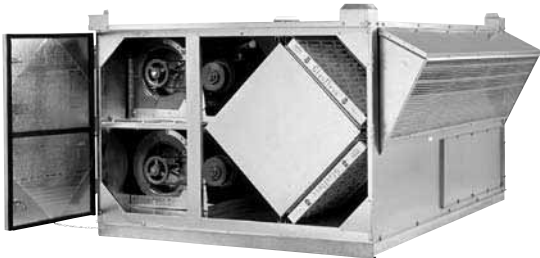

## Specifications

Ventilation Type: Static Plate, Heat and Humidity Transfer						
Typical Airflow Range: 1,000-4,400 CFM						
AHRI 1060 Certified Core: Four L125-00						
Airflow Rating Points (for AHRI): 3,000 CFM and 2,250 CFM						
Number Motors: Two						
HP	Volts	HZ	Phase	FLA	Min. Cir. Amps	Max. Fuse Size
2	208-230	60	Single	11.3-10.5	25.4	35
	208-230	60	Three	6.2-6.2	14.0	20
	460	60	Three	3.5	7.9	15
	575	60	Three	2.3	5.2	15
3	208-230	60	Single	13.7	30.8	45
	208-230	60	Three	9.2-8.6	20.7	30
	460	60	Three	4.3	9.7	15
	575	60	Three	3.2	7.2	15
5	208-230	60	Three	14.0-13.0	31.5	45
	460	60	Three	6.5	14.6	20
	575	60	Three	5.0	11.3	15
	Control Voltage: 24 VAC					
Filters: Eight total, MERV 8, 2" pleated, 20" x 20" nominal size						
Weight: 915 lbs (unit), 1,000 lbs (shipping weight)						
Shipping Dimensions: 84" W x 92" L x 49" H						

## G5 Performance

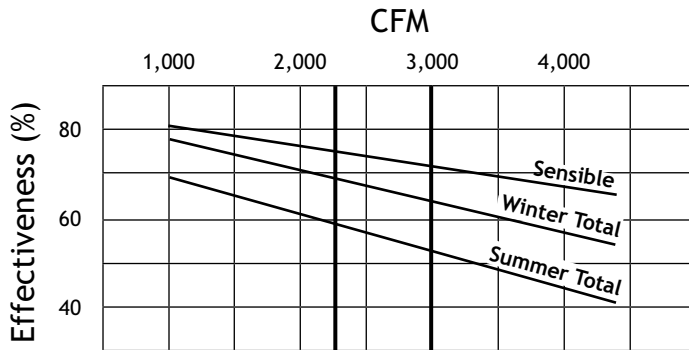

\*At AHRI 1060 standard conditions  
(See certified data on page 67 for core components).

## Base Type/Airflow Orientations

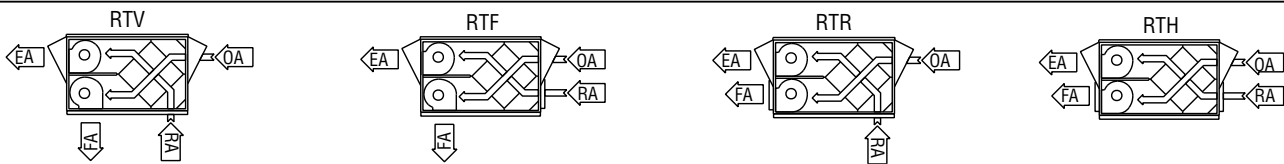

## Airflow Performance

Motor HP	Blower RPM Nominal	Turns Open	External Static Pressure (Inches Water Column)													
			0.0		0.25		0.5		0.75		1.0		1.25		1.5	
			CFM	BHP	CFM	BHP	CFM	BHP	CFM	BHP	CFM	BHP	CFM	BHP	CFM	BHP
2	1,010	4.5	2,489	0.9	2,200	0.9	1,715	0.8	1,100	0.7	-	-	-	-	-	-
	1,210	2	2,995	1.6	2,290	1.5	2,430	1.4	2,005	1.3	1,540	1.2	-	-	-	-
	1,370	0	-	-	-	-	-	-	2,600	2.0	2,215	1.9	1,800	1.7	1,100	1.5
3	1,345	4.5	3,295	2.1	3,145	2.1	2,840	2.0	2,509	1.9	2,116	1.8	1,747	1.6	1,135	1.5
	1,535	2	3,832	2.9	3,682	2.9	3,480	2.8	3,170	2.6	2,839	2.4	2,449	2.3	1,878	2.0
	1,685	0	-	-	-	-	-	-	-	-	3,409	3.0	3,003	2.8	2,465	2.4
5	1,495	6	3,718	2.7	3,568	2.6	3,345	2.6	3,030	2.4	2,686	2.2	2,301	2.1	1,722	1.9
	1,675	3	4,223	3.8	4,083	3.7	3,943	3.6	3,659	3.4	3,364	3.2	2,994	2.9	2,490	2.7
	1,855	0	-	-	-	-	-	-	4,287	4.9	4,011	4.6	3,760	4.3	3,434	4.0

# HE4XRT UNIT DIMENSIONS

EA: Exhaust Air to outdoors  
 OA: Outdoor Air Intake  
 RA: Room Air to be exhausted  
 FA: Fresh Air to inside

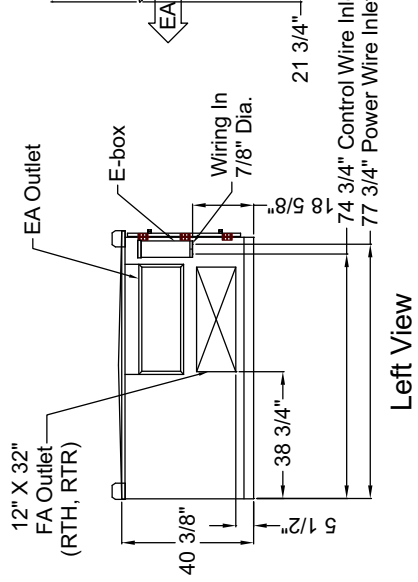
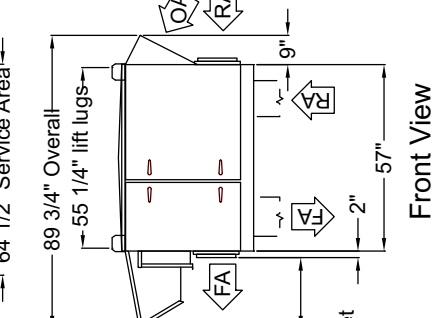
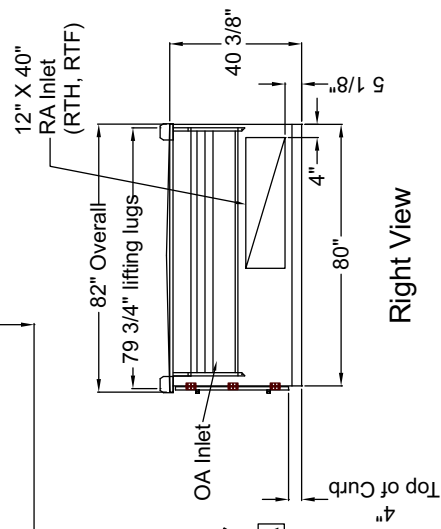
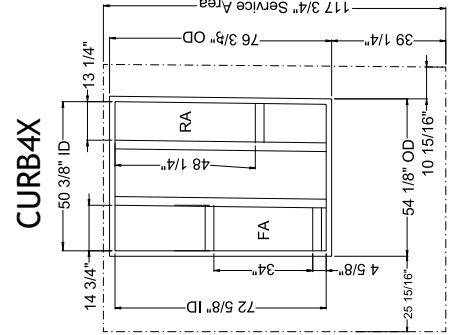
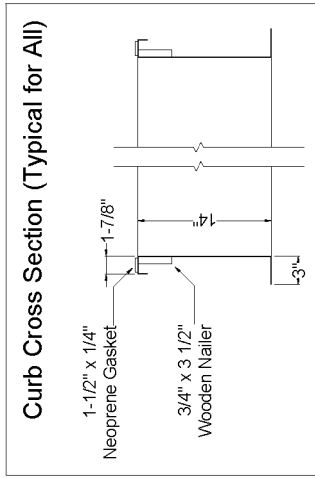
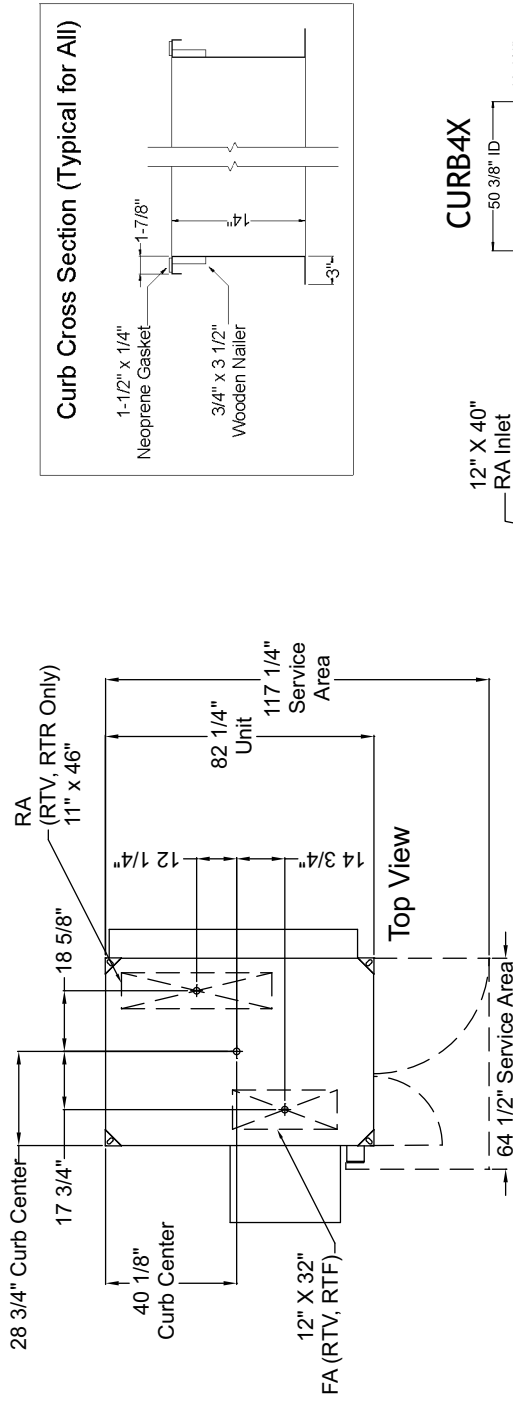

# HE4XRTC



## Outdoor Unit

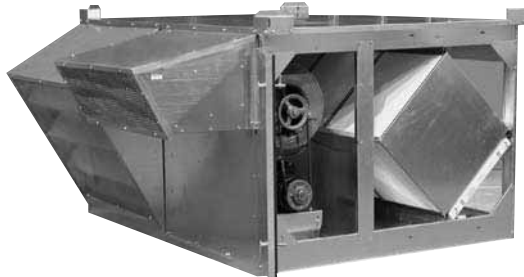

## Specifications

Ventilation Type: Static Plate, Heat and Humidity Transfer						
Typical Airflow Range: 2,500-3,700 CFM						
AHRI 1060 Certified Core: Four L125-00						
Airflow Rating Points (for AHRI): 3,000 CFM and 2,250 CFM						
Number Motors: Two						
HP	Volts	HZ	Phase	FLA	Min. Cir. Amps	Max. Fuse Size
5	208-230	60	Three	14.0-13.0	31.5	45
	460	60	Three	6.5	14.6	20
	575	60	Three	5.0	11.3	15
Control Voltage: 24 VAC						
Filters: Six total, MERV 8, 2" pleated, four 20" x 20", and two 16" x 25" nominal size						
Weight: 965 lbs (unit), 1,050 lbs (shipping weight)						
Shipping Dimensions: 84" W x 92" L x 50" H						

## G5 Performance

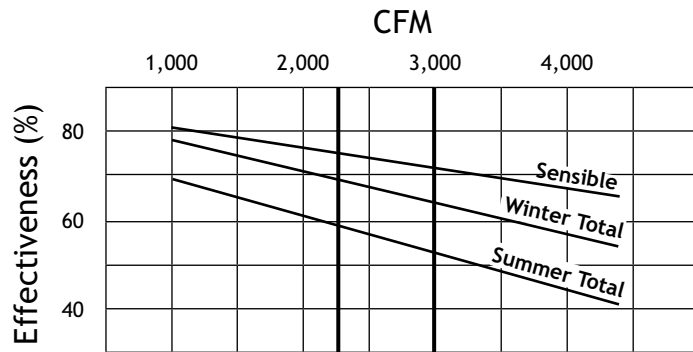

\*At AHRI 1060 standard conditions  
(See certified data on page 67 for core components).

## Airflow Performance

	Blower RPM Nominal	Turns Open	Static Pressure in Adjacent Air Handler (Inches Water Column)									
			-0.5		-0.25		0.0		+0.25		+0.5	
			CFM	BHP	CFM	BHP	CFM	BHP	CFM	BHP	CFM	BHP
Exhaust Air	1,600	0	3,700	3.6	4,000	3.8	4,250	4.3	-	-	-	-
	1,555	1	3,575	3.5	3,900	3.6	4,220	3.9	4,325	4.3	4,380	4.6
	1,515	2	3,415	3.2	3,740	3.5	4,135	3.8	4,275	4.2	4,340	4.5
	1,470	3	3,235	2.9	3,600	3.2	4,000	3.6	4,215	4.0	4,300	4.3
	1,430	4	3,085	2.7	3,455	3.0	3,820	3.2	4,140	3.6	4,260	3.8
	1,385	5	2,980	2.5	3,280	2.7	3,640	2.9	3,985	3.2	4,170	3.4
	1,340	6	2,880	2.3	3,135	2.5	3,475	2.7	3,840	2.9	4,080	3.0
Fresh Air	1,805	1	-	-	-	-	-	-	-	-	3,210	4.9
	1,755	2	-	-	-	-	3,410	4.9	3,190	4.6	3,110	4.3
	1,705	3	3,710	5.0	3,585	4.9	3,310	4.5	3,130	4.2	3,010	3.9
	1,655	4	3,600	4.8	3,470	4.6	3,210	4.2	3,030	3.8	2,910	3.6
	1,605	5	3,510	4.3	3,335	4.1	3,110	3.7	2,920	3.4	2,800	3.2
	1,555	6	3,400	3.9	3,220	3.8	3,010	3.4	2,810	3.2	2,710	3.0

# HE4XRTC UNIT DIMENSIONS

EA: Exhaust Air to outdoors  
 OA: Outdoor Air Intake  
 RA: Room Air to be exhausted  
 FA: Fresh Air to inside

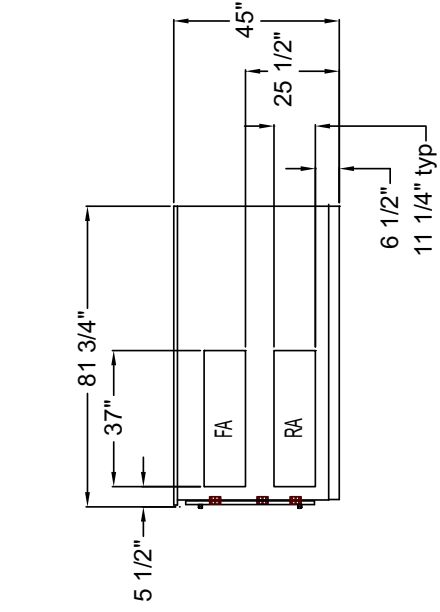
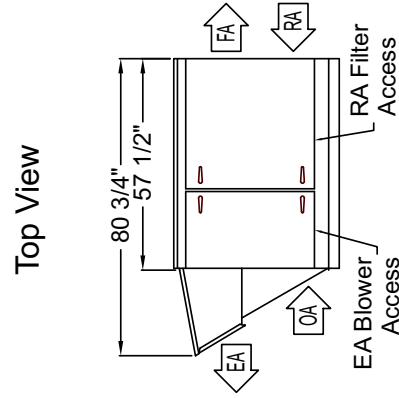
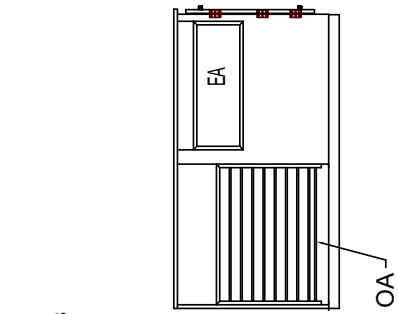
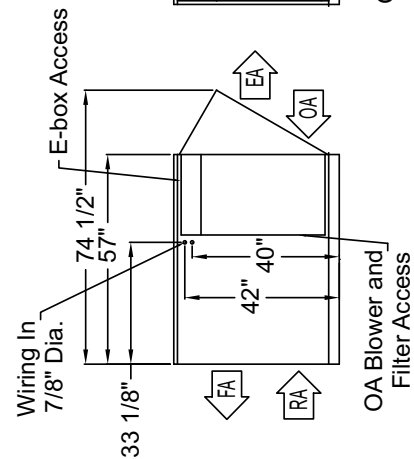
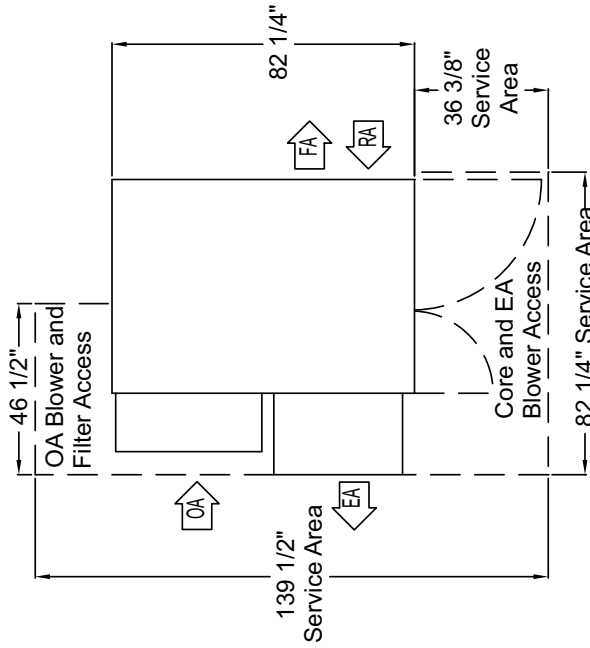

Top View

Front View

Left View

Back View

Right View

# HE6XRT



## Outdoor Unit

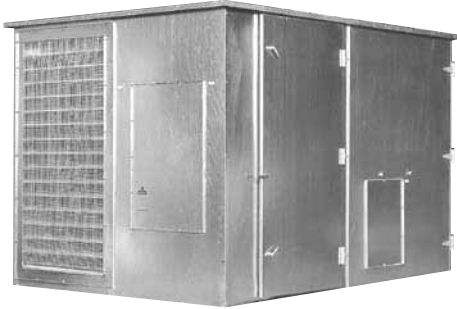

## Specifications

Ventilation Type: Static Plate, Heat and Humidity Transfer						
Typical Airflow Range: 1,500-6,500 CFM						
AHRI 1060 Certified Core: Six L125-00						
Airflow Rating Points (for AHRI): 4,500 CFM and 3,375 CFM						
Number Motors: Two						
HP	Volts	HZ	Phase	FLA	Min. Cir. Amps	Max. Fuse Size
5	208-230	60	Three	14.2-13.0	32.6	45
	460	60	Three	6.5	14.9	20
	575	60	Three	5.0	11.3	15
7.5	208-230	60	Three	20.9-19.2	47.0	70
	460	60	Three	9.6	21.6	30
	575	60	Three	7.6	17.1	25
Control Voltage: 24 VAC						
Filters: Twelve total, MERV 8, 2" pleated, 20" x 20" nominal size						
Weight: 2,340 lbs (unit), 2,640 lbs (shipping weight)						
Shipping Dimensions: 85" W x 114" L x 85" H						

## G5 Performance

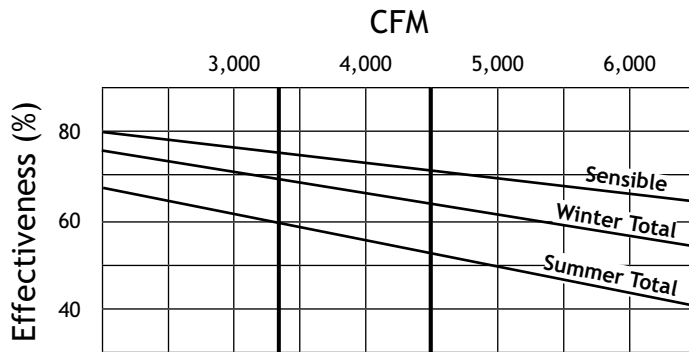

\*At AHRI 1060 standard conditions  
(See certified data on page 67 for core components).

## Base Type / Airflow Orientations

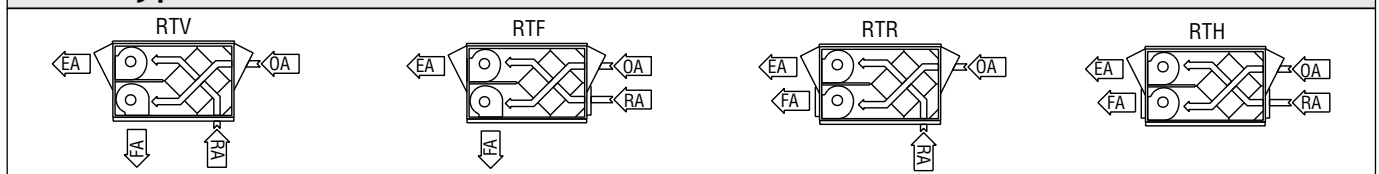

## Airflow Performance

Motor HP	Blower RPM Nominal	Turns Open	External Static Pressure (Inches Water Column)													
			0.0		0.25		0.5		0.75		1.0		1.25		1.5	
			CFM	BHP	CFM	BHP	CFM	BHP	CFM	BHP	CFM	BHP	CFM	BHP	CFM	BHP
5	1,460	4.5	5,005	3.2	4,800	3.2	4,650	3.1	4,475	3.0	4,200	2.9	4,000	2.8	3,750	2.8
	1,610	2	5,550	4.2	5,375	4.2	5,250	4.1	5,100	4.1	4,900	4.0	4,650	3.9	4,500	3.8
	1,725	0	-	-	-	-	-	-	5,525	5.0	5,475	5.0	5,200	4.9	5,050	4.8
7.5	1,560	4.5	5,275	3.7	5,200	3.6	4,900	3.5	4,775	3.5	4,550	3.4	4,350	3.3	4,125	3.3
	1,740	2	5,950	5.0	5,825	5.0	5,625	4.9	5,490	4.9	5,325	4.8	5,125	4.7	4,950	4.7
	1,865	0	6,500	6.5	6,350	6.5	6,225	6.4	6,125	6.4	5,910	6.3	5,825	6.2	5,625	6.1



# HE6XR UNIT DIMENSIONS

EA: Exhaust Air to outdoors  
 OA: Outdoor Air Intake  
 RA: Room Air to be exhausted  
 FA: Fresh Air to inside

**Curb Cross Section (Typical for All)**

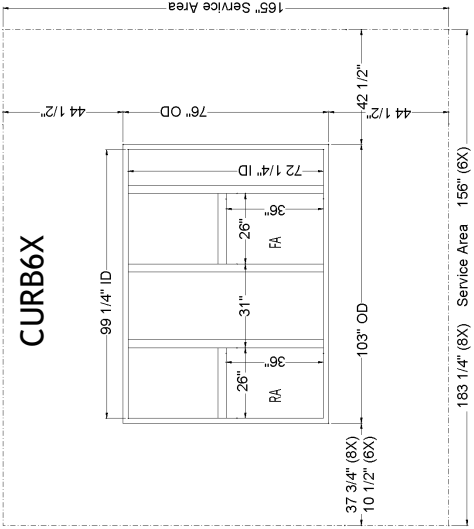
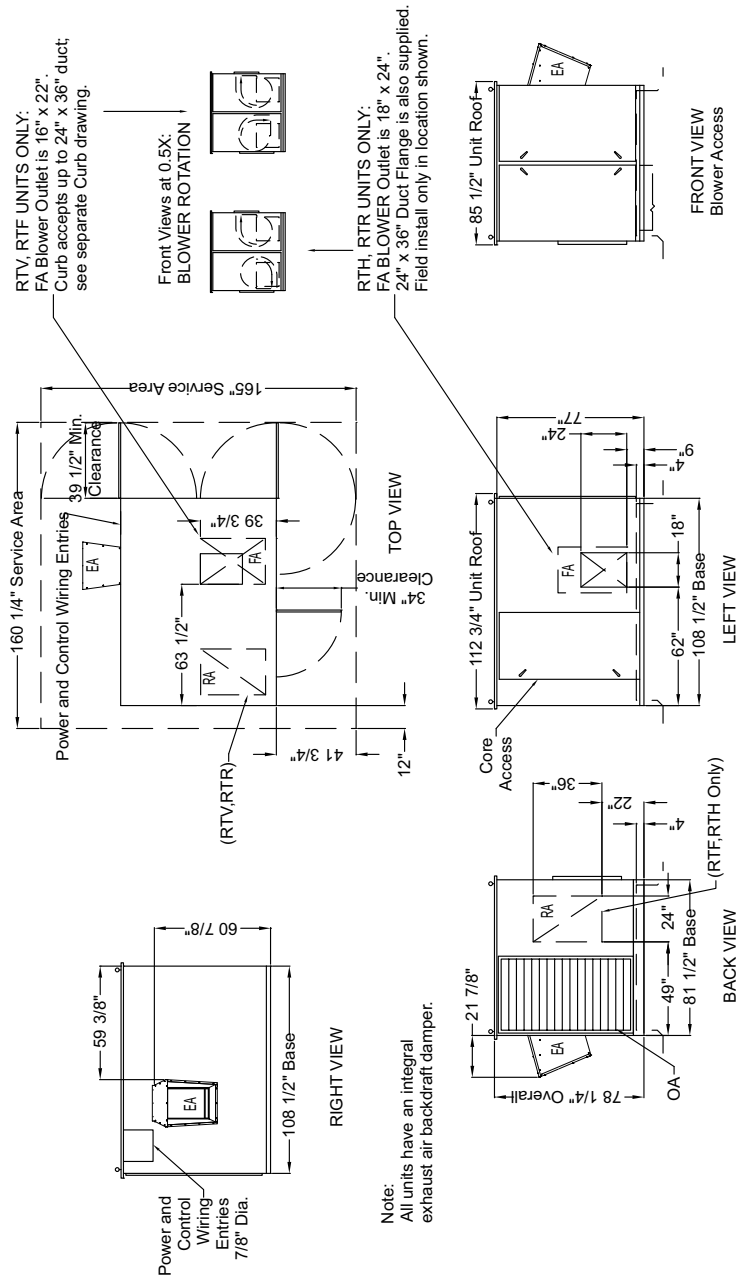
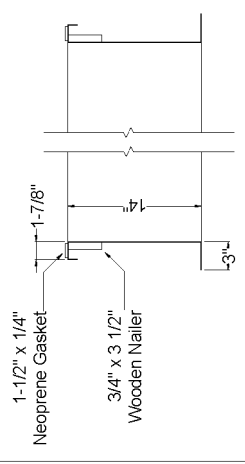

Note:  
 All units have an integral exhaust air backdraft damper.

# HE8XRT



## Outdoor Unit



## Specifications

Ventilation Type: Static Plate, Heat and Humidity Transfer						
Typical Airflow Range: 2,000-8,000 CFM						
AHRI 1060 Certified Core: Eight L125-00						
Airflow Rating Points (for AHRI): 6,000 CFM and 4,500 CFM						
Number Motors: Two						
HP	Volts	HZ	Phase	FLA	Min. Cir. Amps	Max. Fuse Size
5	208-230	60	Three	14.2-13.0	32.6	45
	460	60	Three	6.5	14.9	20
	575	60	Three	5.0	11.3	15
7.5	208-230	60	Three	20.9-19.2	47.0	70
	460	60	Three	9.6	21.6	30
	575	60	Three	7.6	17.1	25
10	208-230	60	Three	29.0-26.8	65.3	90
	460	60	Three	13.4	30.2	45
	575	60	Three	10.0	22.5	35
Control Voltage: 24 VAC						
Filters: Sixteen total, MERV 8, 2" pleated, 20" x 20" nominal size						
Weight: 2,730 lbs (unit), 3,080 lbs (shipping weight)						
Shipping Dimensions: 85" W x 114" L x 85" H						

## G5 Performance

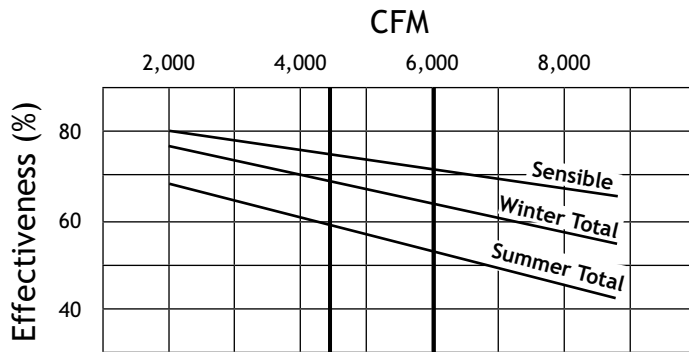

\*At AHRI 1060 standard conditions  
(See certified data on page 67 for core components).

## Base Type/Airflow Orientations

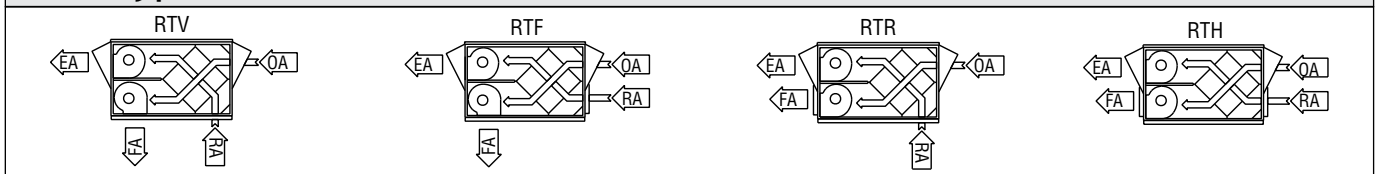

## Airflow Performance

Motor HP	Blower RPM Nominal	Turns Open	External Static Pressure (Inches Water Column)													
			0.0		0.25		0.5		0.75		1.0		1.25		1.5	
			CFM	BHP	CFM	BHP	CFM	BHP	CFM	BHP	CFM	BHP	CFM	BHP	CFM	BHP
5	1,460	4.5	5,575	3.2	5,425	3.2	5,200	3.2	5,000	3.2	4,775	3.1	4,550	3.0	4,270	2.9
	1,610	2	6,200	4.3	6,010	4.3	5,875	4.2	5,700	4.2	5,500	4.2	5,325	4.1	5,125	4.1
	1,725	0.5	6,550	5.0	6,380	5.0	6,210	5.0	6,100	5.0	5,880	4.9	5,730	4.8	5,510	4.8
7.5	1,560	4.5	6,000	3.9	5,850	3.9	5,650	3.8	5,475	3.8	5,275	3.8	5,100	3.7	4,875	3.7
	1,740	2	6,700	5.3	6,575	5.3	6,400	5.3	6,300	5.3	6,125	5.3	5,950	5.2	5,750	5.2
	1,865	0	-	-	-	-	-	-	6,800	7.5	6,675	7.5	6,500	7.5	6,375	7.4
10	1,810	4.5	7,000	6.1	6,875	6.1	6,750	6.1	6,600	6.0	6,425	6.0	6,275	6.0	6,100	5.9
	2,020	2	7,850	8.5	7,745	8.5	7,625	8.5	7,450	8.4	7,350	8.4	7,200	8.3	7,050	8.3
	2,105	1	-	-	-	-	7,950	9.6	7,800	9.6	7,725	9.6	7,600	9.5	7,450	9.5



# APPLIED PRODUCTS

- Cost effective energy recovery for virtually any air handling system.
- Field assembled into air handling systems or integrated in custom packaged air handlers.
- Unlimited airflow capacity.
- Flexible installation and easy servicing.
- AHRI certified performance data for efficiency and cross leakage.
- UL tested flammability and smoke generation that meets NFPA 90A and 90B test standards for commercial applications.
- Ten year core warranty.

RenewAire means *Trouble-Free* ERV.

## Installation Example

Central Air Handler using CA4X and exhaust and make-up air blowers.  
 (CA-Series provide side service access and a "side-by-side" airflow arrangement.)

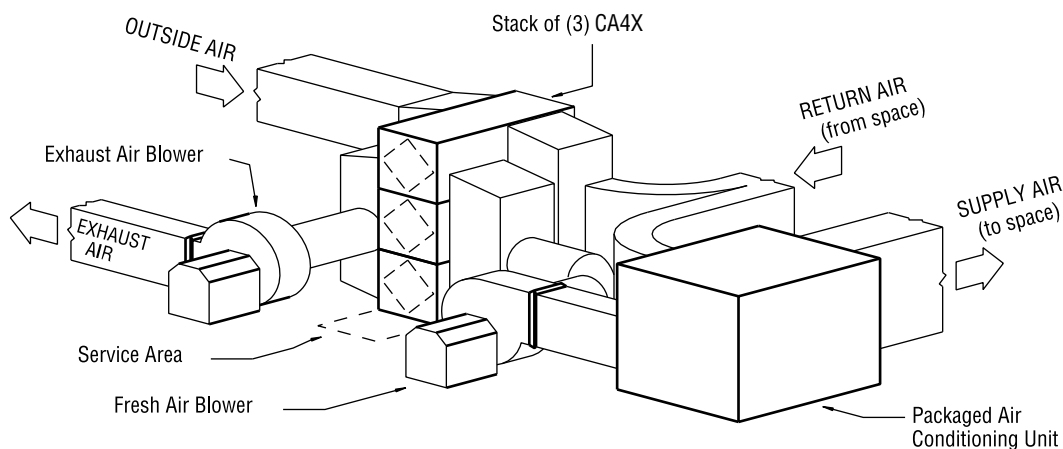

Similar designs can use PA-Series arrays.  
 (PA-Series provide top service access and an "over-under" airflow arrangement.)

# CA & PA Series Applied Energy Recovery Ventilators: CA2X, CA3X, CA4X, PA6X, PA9X, PA8X & PA12X

## Part I - General

### A. Product Specification

1. Energy Recovery Ventilator (ERV) shall be a packaged unit as manufactured by RenewAire and shall transfer both heat and humidity using static plate core technology.

### B. Quality Assurance

1. The energy recovery cores used in these products shall be third party Certified by AHRI under its Standard 1060 for Energy Recovery Ventilators. AHRI published certifications shall confirm manufacturer's published performance for airflow, static pressure, temperature and total effectiveness, purge air (OACF) and exhaust air leakage (EATR). Products that are not currently AHRI Certified will not be accepted.

2. The energy recovery core shall be a UL Listed Component complying to UL Standard 723. Manufacturer shall be able to provide evidence of independent testing of the core by Underwriters Laboratory (UL), verifying a maximum flame spread index (FSI) of 25 and a maximum smoke developed index (SDI) of 50 thereby meeting NFPA 90A and NFPA 90B requirements for materials in a compartment handling air intended for circulation through a duct system.

3. The ERV core shall be warranted to be free of manufacturing defects and to retain its functional characteristics, under circumstances of normal use, for a period of ten years from the date of purchase. The balance-of-unit shall be warranted to be free of manufacturing defects and to retain its functional characteristics, under circumstances of normal use, for a period of two years from the date of purchase.

## Part II - Performance

### A. Energy Transfer

The ERV shall be capable of transferring both sensible and latent energy between airstreams. Latent energy transfer shall be accomplished by direct water vapor transfer from one airstream to the other, without exposing transfer media in succeeding cycles directly to the exhaust air and then to the fresh air.

### B. Passive Frost Control

The ERV core shall perform without condensing or frosting under normal operating conditions (defined as outside temperatures above -10°F and inside relative humidity below 40%). Occasional more extreme conditions shall not affect the usual function, performance or durability of the core. No condensate drains will be allowed.

### C. Continuous Ventilation

Unit shall have the capacity to operate continuously without the need for bypass, recirculation, pre-heaters or defrost cycles under normal operating conditions.

### D. Positive Airstream Separation

Water vapor transfer shall be through molecular transport by hydroscopic resin and shall not be accomplished by "porous plate" mechanisms. Exhaust and fresh airstreams shall travel at all times in separate passages, and airstreams shall not mix.

### E. Laminar Flow

Airflow through the ERV core shall be laminar over the products entire operating airflow range, avoiding deposition of particulates on the interior of the energy exchange plate material.

## Part III - Product

### A. Construction

1. The energy recovery component shall be of fixed-plate cross-flow construction, with no moving parts.

2. No condensate drain pans or drains shall be allowed and unit shall be capable of operating in both winter and summer conditions without generating condensate.

3. The unit case shall be constructed of G90 galvanized, 20-gauge steel, with lapped corners and zinc plated screw fasteners.

4. Access doors shall provide easy access to ERV cores and filters. Doors shall have an airtight compression seal using closed cell foam gaskets.

5. Case walls and doors shall be insulated with 1 inch, 4 pound density, foil/scrim faced, high-density fiberglass board insulation, providing a cleanable surface and eliminating the possibility of exposing the fresh air to glass fibers. PA-Series bottom panels shall be insulated with ¼ inch sheet rubber insulation.

6. The ERV cores shall be protected by a MERV-8 rated, 2" nominal, pleated, disposable filter in both airstreams.

7. CA-Series cabinet construction shall allow stacking of units up to three cabinets high for larger airflow applications. Hinged and latched access doors will be provided on each end of the unit.

8. PA-Series shall use RenewAire patented modular vertical stack of cores (US Patent 5,660,228) allowing assembly of unlimited sizes of ERV systems. Latched access doors are provided on the top of each unit.

### B. Options *(Select options based on application requirements)*

1. Provide unit and duct connection orientation per project schedule.

2. Provide double wall construction with 24-gauge galvanized steel liner (CA-Series only).

3. CA and PA-Series units are available pre-assembled on a structural steel base.

## Part IV - Installation

### A. Unit Location

1. Locate and orient unit to provide the shortest and most straight duct connections. Provide service clearances as indicated on the plans. Locate system blowers (provided by others) distant from sound critical occupancies.

2. Provide a poured concrete equipment pad for all floor mounted units. The pad thickness, and floor plan dimensions to be determined based on the unit selected, and site structural considerations.

3. Provide a structurally suitable support for the base of any wall mounted or hung units.

### B. Vibration Isolation

1. No moving parts are allowed in the ERV modular assemblies.

### C. Duct Design

1. All ductwork shall be designed, constructed, supported and sealed in accordance with SMACNA HVAC Duct Construction Standards and pressure classifications.

2. At a minimum all duct runs to the outdoors shall be thermally insulated at levels appropriate to the local climate. A continuous vapor barrier shall also be provided on warm surface of the insulation.

### D. Sound Control

1. The ERV cores shall act as flow straighteners and sound attenuators. This attribute can be used to isolate mechanical noise from blowers and other mechanical equipment from sound critical occupancies.

### E. Test and Balancing

1. Test and Balancing may not begin until 100% of the installation is complete and fully functional.

2. Follow National Comfort Institute (NCI) air test and balance procedures specific to Heat Recovery Ventilator Balancing Procedure including standard reports to the owner's representative.

# CA-SERIES



## Indoor Unit - Up to 20,000 CFM in Stacked Arrays

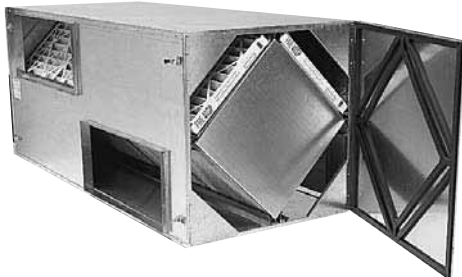

## Specifications

Ventilation Type: Static Plate, Heat and Humidity Transfer			
Insulated sheet metal cabinets with energy exchange cores and filters.			
Individual CA-Series units or stacks of units can be built into larger air handling systems.			
Blower not included and must be specified to meet job requirements.			
Description	CA2X	CA3X	CA4X
Typical Airflow Range CFM	500-2,200	750-3,300	1,000-4,400
AHRI 1060 Certified Core	Two L125-00	Three L125-00	Four L125-00
Airflow Rating Points (for AHRI)	1,500 and 1,120 CFM	2,250 and 1,690 CFM	3,000 and 2,250 CFM
Unit Weight	225 lbs	325 lbs	400 lbs
Shipping Weight	275 lbs	375 lbs	475 lbs
Filters: MERV 8, 2" pleated 20" x 20" nominal size	Four Total	Six Total	Eight Total
Shipping Dimensions: CA2X - 40" W x 48" L x 41" H CA3X - 40" W x 67" L x 41" H CA4X - 40" W x 87" L x 41" H			
Insulation: One inch, high density, FSK faced, fiberglass			

## G5 Performance

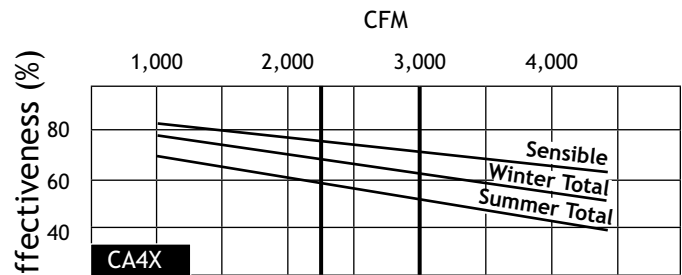
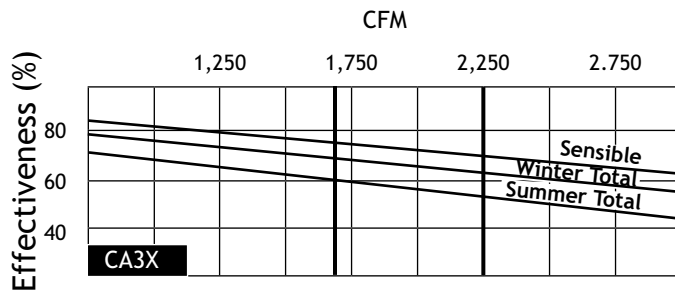
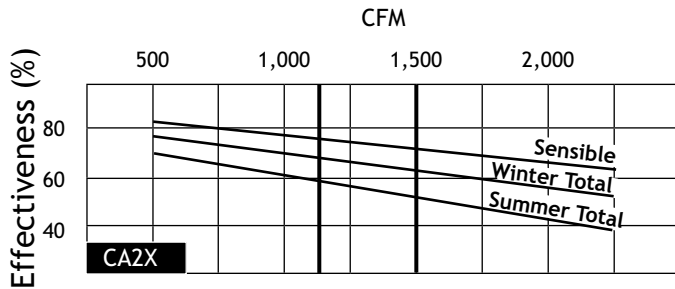

\*At AHRI 1060 standard conditions  
(See certified data on page 66 for core components).

## Airflow Performance

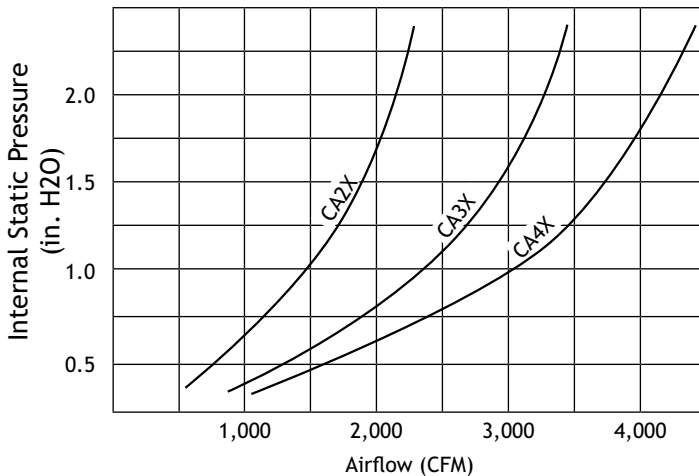

# CA-SERIES UNIT DIMENSIONS

	CA2X	CA3X	CA4X
A	42"	62"	81-5/8"
B	14"	24"	32"
C	111"	130"	149"
D	77"	96"	116"
E	5-5/8"	5-5/8"	7-5/8"
F	19-3/4"	29-5/8"	39-3/4"

Available Options:  
Double Wall Construction

EA: Exhaust Air to outdoors  
OA: Outdoor Air Intake  
RA: Room Air to be exhausted  
FA: Fresh Air to inside

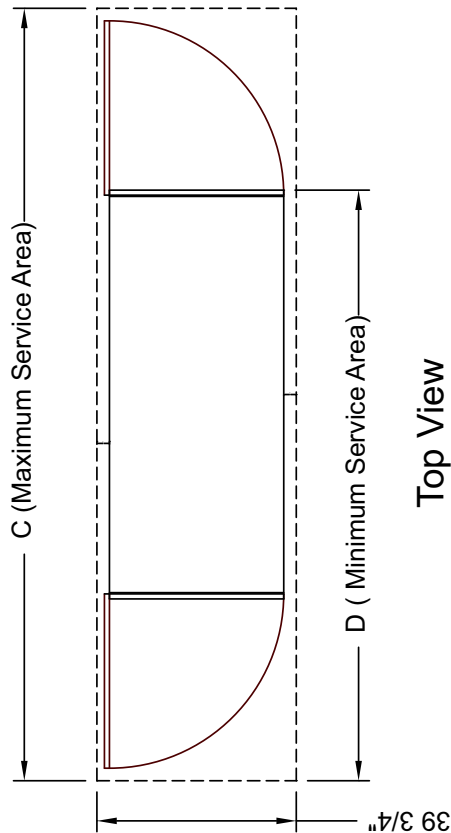

Top View

Note: Filters are provided for installation in any two of the locations shown, depending on which duct connections are selected for inlets.  
Filters are 2" x 20" x 20" pleated disposable.

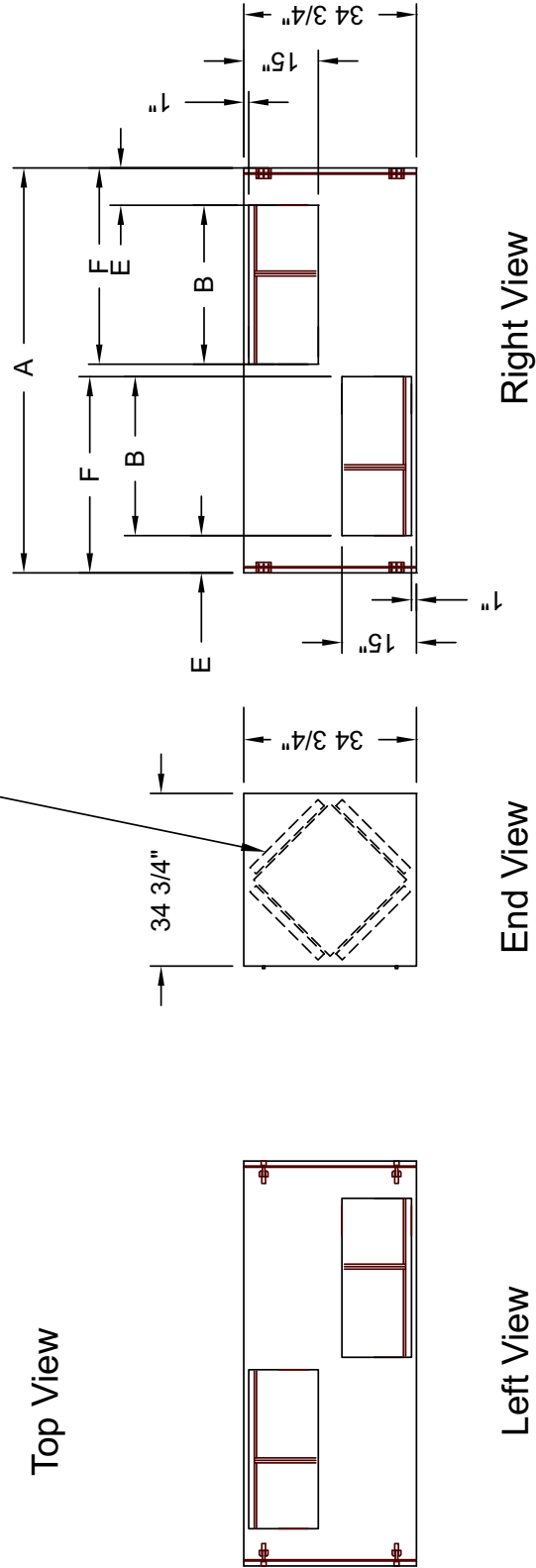

Left View

End View

Right View

# PA-SERIES



## Indoor Unit - Unlimited Airflow in Multiple Arrays



## Specifications

Ventilation Type: Static Plate, Heat and Humidity Transfer				
Insulated sheet metal panels easily slide into receivers to enclose stacks of energy exchange cores using unique patented design, US Patent 5,660,228				
Individual PA-Series units can be joined together to provide unlimited airflow capacities for larger air handling systems.				
Blower not included and must be specified to meet job requirements.				
Description	PA6X	PA8X	PA9X	PA12X
Typical Airflow Range CFM	1,500-6,600	2,000-8,800	2,250-9,900	3,000-13,200
AHRI 1060 Certified Core	Six L125-00	Eight L125-00	Nine L125-00	Twelve L125-00
Airflow Rating Points (for AHRI)	4,500 and 3,375 CFM	6,000 and 4,500 CFM	6,750 and 5,062 CFM	9,000 and 6,750 CFM
Unit Weight	565 lbs	695 lbs	800 lbs	980 lbs
Shipping Weight	650 lbs	900 lbs	990 lbs	1,180 lbs
Filters: MERV 8, 2" pleated, 20" x 20" nominal size PA6X - 12 Total      PA9X - 18 Total PA8X - 16 Total      PA12X - 24 Total				
Insulation: One inch, high density, FSK faced, fiberglass				

## G5 Performance

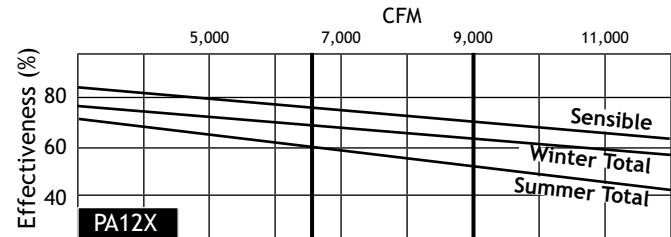
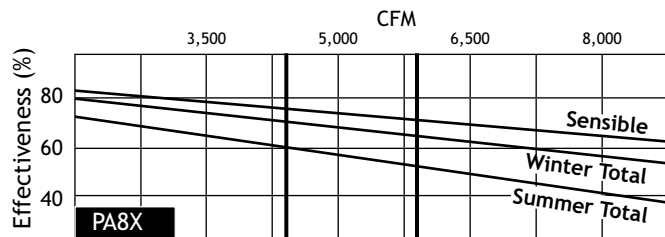
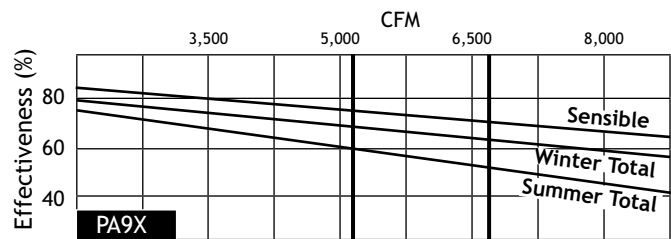
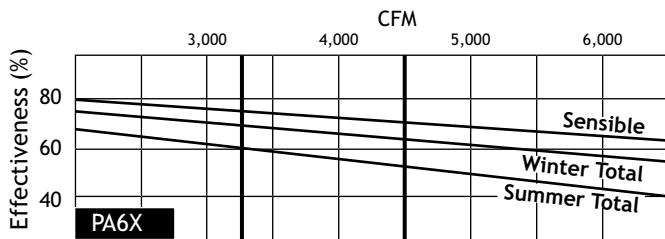

\*At AHRI 1060 standard conditions  
(See certified data on page 66 for core components).

## Airflow Performance

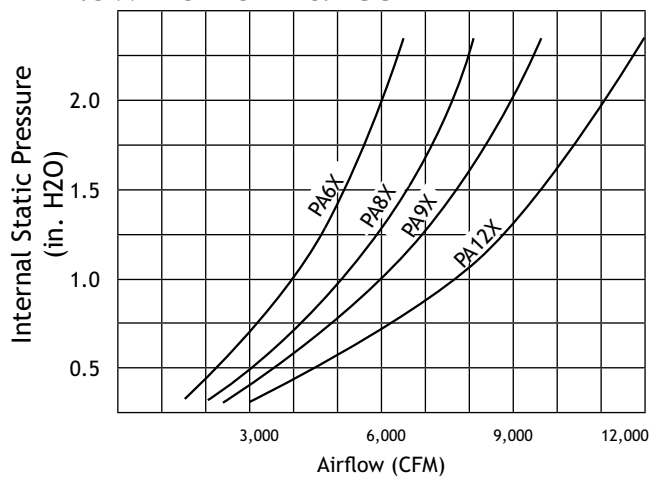



# PA-SERIES UNIT DIMENSIONS

EA: Exhaust Air to outdoors  
 OA: Outdoor Air Intake  
 RA: Room Air to be exhausted  
 FA: Fresh Air to inside

Available Options:  
 Knockdown  
 Assembled on structural  
 forklift base

	PA6X	PA9X	PA8X	PA12X
A	73-1/4"	109-1/2"	73-1/4"	109-1/2"
D	72-3/4"	109"	72-3/4"	109"
E	28"	28"	37"	37"
F	1-1/2"	1-1/2"	3-1/8"	3-1/8"
G	66-1/4"	66-1/4"	86"	86"
APPROX. WEIGHT	565	810	700	1000

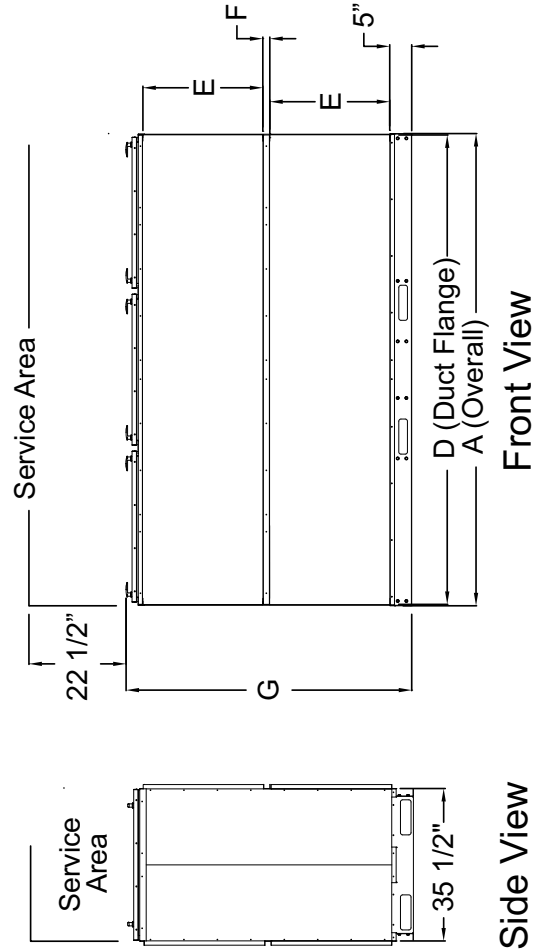
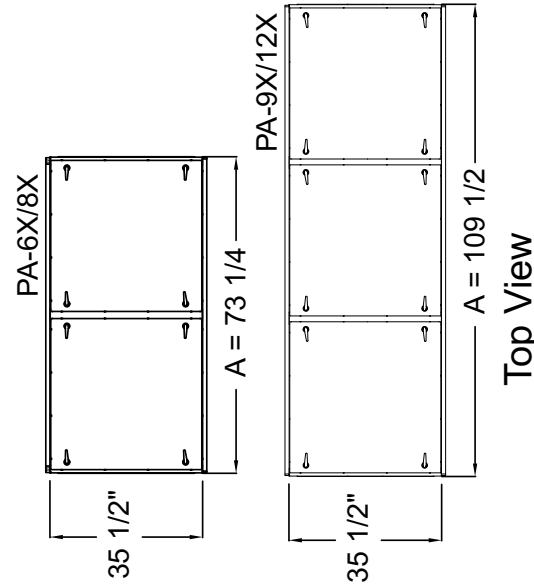

## Available Airflow Arrangements (Side Views)

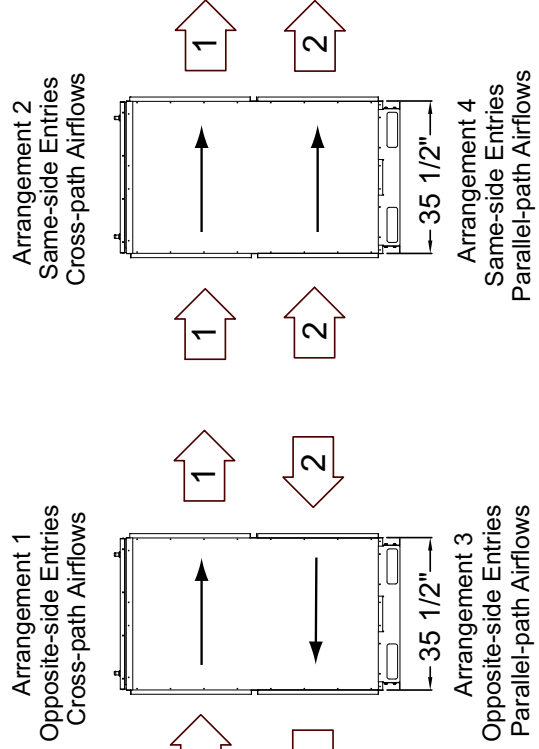
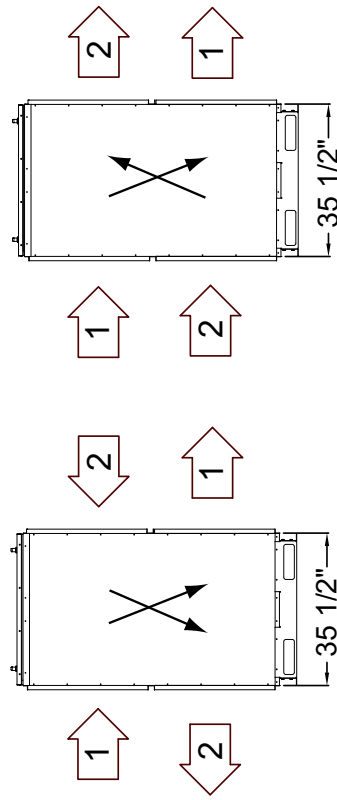

### Performance Derating:







Airflow arrangements 3 & 4 result in lower energy transfer.  
 Reduce sensible effectiveness by 2 percentage points.  
 Reduce total effectiveness by 1 percentage point.

# COMMERCIAL CONTROLS & INTERCONNECTION OPTIONS

These controls are intended to turn RenewAire commercial energy recovery ventilation systems on and off at appropriate times. Specification, installation and set-up is an easy process. RenewAire units should be ordered with the 24 volt contactor option for all controls.

It is not necessary that RenewAire controls be used to operate RenewAire units. A wide range of controls or building automation systems may be used. Make sure units are ordered with compatible contactor control voltage.

RenewAire residential units have their own line of compatible controls that are not intended to operate RenewAire commercial units.

<h2>TC7D</h2> 	<h3>DIGITAL TIME CLOCK</h3> <ul style="list-style-type: none"> <li>• up to 8 on/off cycles per day or 56 per week</li> <li>• 24 VAC power requirement</li> <li>• battery back-up</li> <li>• wall mount or outdoor enclosure options</li> <li>• wall mount fits any 4" x 4" electrical box</li> <li>• optional RenewAire transformer relay package (TR40) may be used</li> </ul>	 <ul style="list-style-type: none"> <li>TC7D-W Wall Mount</li> <li>TC7D-E Control In NEMA 3R Enclosures</li> </ul>
<h2>MC</h2> 	<h3>MOTION (OCCUPANCY) CONTROL</h3> <ul style="list-style-type: none"> <li>• passive infrared sensor</li> <li>• adjustable time-off delay to 30 minutes</li> <li>• 24 VAC power requirement</li> <li>• ceiling mount or directable wall mount</li> <li>• covers up to 1500 sq. ft. floor space                     <ul style="list-style-type: none"> <li>ceiling mount - walking motion coverage up to 22 foot radius</li> <li>wall mount - various coverage patterns up to 90 linear feet of sensitivity</li> </ul> </li> <li>• requires the use of RenewAire transformer relay package (TR40) (ordered separately)</li> </ul>	 <ul style="list-style-type: none"> <li>MC-C Ceiling Mount</li> <li>MC-W Wall Mount</li> </ul>
<h2>CO2</h2> 	<h3>CARBON DIOXIDE CONTROL</h3> <ul style="list-style-type: none"> <li>• adjustable control from 600-2000 PPM</li> <li>• digital display</li> <li>• 24 VAC power requirement</li> <li>• computer/BAS interface for information and control</li> <li>• self calibrates during periods of low occupancy</li> <li>• wall mount or add duct mount accessory</li> <li>• requires the use of RenewAire transformer relay package (TR40) (ordered separately)</li> </ul>	 <ul style="list-style-type: none"> <li>CO2-W Wall Mount</li> <li>CO2-D Duct Mount</li> </ul>

## DH24

## DEHUMIDISTAT CONTROL

DH24  
Wall Mount



- secondary control to time clock or other primary control
- mechanical switching of 24 VAC (or 120 VAC)
- adjustable from 0 - 100% relative humidity
- wall mount to single gang box
- Note: RenewAire ERVs are not to be used for applications where indoor relative humidity exceeds 50% RH for extended periods of time

## DS

## DISCONNECT SWITCH



- fused or non-fused
- indoor or NEMA 3R exterior enclosures - I or E
- installation voltage must be specified 115, 208-230, 460
- installed on unit and wired to unit contactor
- disconnects are configured as part of the model numbering for a unit (see page 67)

## TR40

## TRANSFORMER RELAY PACKAGE

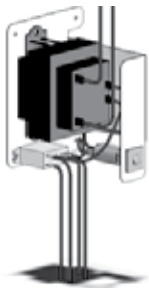

- provides a 24 VAC, 40 VA class II power supply for unit control
- includes isolation relay with low voltage circuit breaker
- handles any RenewAire unit with one contactor
- installation voltage must be specified 115, 208-230, 460
- installed in unit electric box
- TR40 is configured as part of the model numbering for a unit (see page 67)

## IBC

## INDEPENDENT BLOWER CONTROL

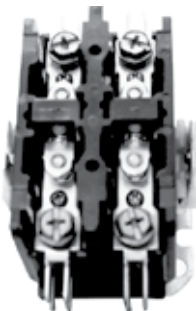

- adds a second contactor to allow independent control of exhaust fan and supply fan
- may be used to provide economizer (no heat recovery operation) function
- can provide relief fan or make-up air function to benefit building pressurization
- IBC is configured as part of the model numbering guide for a unit (see page 67)

# HVI Tested/Certified

Per CSA C439



BR70/EV70 - Ventilation Performance							
Ext. Static Pressure		Net Supply Airflow		Gross Airflow			
Pa		in. wg		Supply		Exhaust	
Pa	in. wg	L/S	CFM	L/S	CFM	L/S	CFM
25	0.1	41	86	42	89	46	97
50	0.2	34	73	35	75	39	84
75	0.3	28	59	29	61	32	69
100	0.4	21	46	22	47	25	53

Electrical Requirements Volts 120 Amps 1.0  
 Exhaust Air Transfer Ratio = 4% @ 0.2 in. wg (50 PA) and 4% @ 0.4 in. wg (100 PA)

BR70/EV70 - Energy Performance						
Supply Temperature		Net Airflow		Average Power	Sensible Recovery	Apparent Sensible
C°	F°	L/S	CFM	Watts	Efficiency %	Effectiveness %
Heating						
0°	32°	32	69	94	66	77
				Total Recovery Efficiency %		
Cooling						
35°	95°	30	64	94	42	

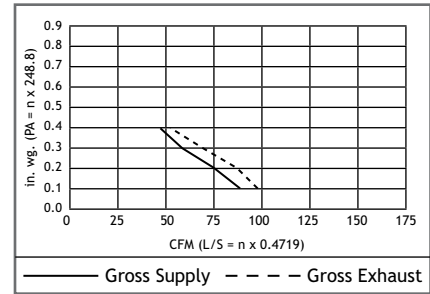

BR130/EV130 - Ventilation Performance							
Ext. Static Pressure		Net Supply Airflow		Gross Airflow			
Pa		in. wg		Supply		Exhaust	
Pa	in. wg	L/S	CFM	L/S	CFM	L/S	CFM
25	0.1	70	148	71	151	75	159
50	0.2	66	141	67	143	69	147
75	0.3	62	132	63	134	64	135
100	0.4	53	113	54	115	56	119
125	0.5	44	94	45	96	47	99
150	0.6	32	69	33	70	29	62
175	0.7	24	52	25	53	21	45

Electrical Requirements Volts 120 Amps 1.3  
 Exhaust Air Transfer Ratio = 2% @ 0.2 in. wg (50 PA) and 2% @ 0.4 in. wg (100 PA)

BR130/EV130 - Energy Performance						
Supply Temperature		Net Airflow		Average Power	Sensible Recovery	Apparent Sensible
C°	F°	L/S	CFM	Watts	Efficiency %	Effectiveness %
Heating						
0°	32°	58	124	121	72	80
				Total Recovery Efficiency %		
Cooling						
35°	95°	59	126	121	46	

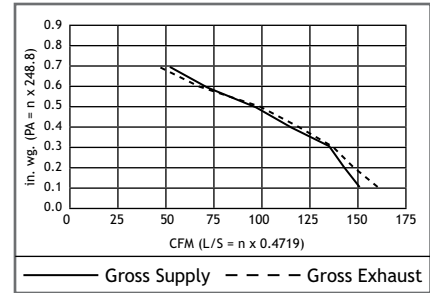

EV200 - Ventilation Performance							
Ext. Static Pressure		Net Supply Airflow		Gross Airflow			
Pa		in. wg		Supply		Exhaust	
Pa	in. wg	L/S	CFM	L/S	CFM	L/S	CFM
25	0.1	97	207	100	213	109	232
50	0.2	90	192	93	199	104	221
75	0.3	88	186	90	192	101	216
100	0.4	83	176	85	181	96	204
125	0.5	79	168	81	173	88	187
150	0.6	70	149	72	154	76	162
175	0.7	57	122	59	126	68	145

Electrical Requirements Volts 120 Amps 1.5  
 Exhaust Air Transfer Ratio = 3% @ 0.2 in. wg (50 PA) and 3% @ 0.4 in. wg (100 PA)

EV200 - Energy Performance						
Supply Temperature		Net Airflow		Average Power	Sensible Recovery	Apparent Sensible
C°	F°	L/S	CFM	Watts	Efficiency %	Effectiveness %
Heating						
0°	32°	85	181	157	78	85
				Total Recovery Efficiency %		
Cooling						
35°	95°	85	180	155	52	

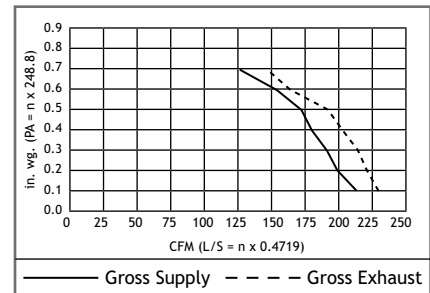

EV300 - Ventilation Performance							
Ext. Static Pressure		Net Supply Airflow		Gross Airflow			
Pa		in. wg		Supply		Exhaust	
Pa	in. wg	L/S	CFM	L/S	CFM	L/S	CFM
100	0.4	145	310	150	320	143	305
125	0.5	141	300	145	310	138	295
150	0.6	136	289	140	299	127	270
175	0.7	126	268	130	276	114	242
200	0.8	117	249	121	251	92	195
225	0.9	94	199	97	206	79	169
250	1.0	73	155	75	160	65	138

Electrical Requirements Volts 120 Amps 3.3  
 Exhaust Air Transfer Ratio = 4% @ 0.4 in. wg (100 PA)

EV300 - Energy Performance						
Supply Temperature		Net Airflow		Average Power	Sensible Recovery	Apparent Sensible
C°	F°	L/S	CFM	Watts	Efficiency %	Effectiveness %
Heating						
0°	32°	138	293	310	68	76
				Total Recovery Efficiency %		
Cooling						
35°	95°	120	272	299	38	

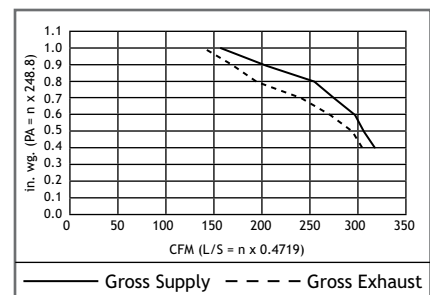

# AHRI 1060-2005

## Certified Performance

AHRI-1060 Certified Performance - Model Number L85-G5													
Type		Tilt Angle			Nominal Airflow				Pressure Drop				
Plate		N/A			100% - 450 SCFM 75% - 338 SCFM				0.6 in. H <sub>2</sub> O 0.5 in. H <sub>2</sub> O				
Leakage Ratings					Thermal Effectiveness Ratings at 0" Pressure Differential								
	Pressure Differential	EATR	OACF	Purge Angle or Setting	Nominal Airflow	Sensible	Latent	Total	Net Airflow	Net Sensible	Net Latent	Net Total	
Test 1	-1 in. H <sub>2</sub> O	1.0%	1.00	N/A	450 Heating CFM Cooling	73% 73%	53% 46%	66% 56%	450 CFM	73% 73%	53% 46%	66% 56%	
Test 2	0 in. H <sub>2</sub> O	0.0%	1.02	N/A	338 Heating CFM Cooling	77% 77%	60% 52%	71% 61%	338 CFM	77% 77%	60% 52%	71% 61%	
Test 3	1 in. H <sub>2</sub> O	0.0%	1.05	N/A									

AHRI-1060 Certified Performance - Model Number L125-G5													
Type		Tilt Angle			Nominal Airflow				Pressure Drop				
Plate		N/A			100% - 750 SCFM 75% - 563 SCFM				0.65 in. H <sub>2</sub> O 0.45 in. H <sub>2</sub> O				
Leakage Ratings					Thermal Effectiveness Ratings at 0" Pressure Differential								
	Pressure Differential	EATR	OACF	Purge Angle or Setting	Nominal Airflow	Sensible	Latent	Total	Net Airflow	Net Sensible	Net Latent	Net Total	
Test 1	-1 in. H <sub>2</sub> O	1.0%	1.00	N/A	750 Heating CFM Cooling	71% 71%	52% 43%	64% 53%	750 CFM	71% 71%	52% 43%	64% 53%	
Test 2	0 in. H <sub>2</sub> O	0.0%	1.02	N/A	563 Heating CFM Cooling	75% 75%	59% 50%	69% 59%	563 CFM	75% 75%	59% 50%	69% 59%	
Test 3	1 in. H <sub>2</sub> O	0.0%	1.05	N/A									

NOTE: SCFM = Standard Cubic Feet per Minute OACF = Outdoor Air Correction Factor EATR = Exhaust Air Transfer Ratio N/A = Not Applicable

Energy recovery component certified in accordance with AHRI Standard 1060-2005.  
Actual performance in packaged equipment may vary.



## MODEL NUMBERING GUIDE *Not all options are available on every model.*

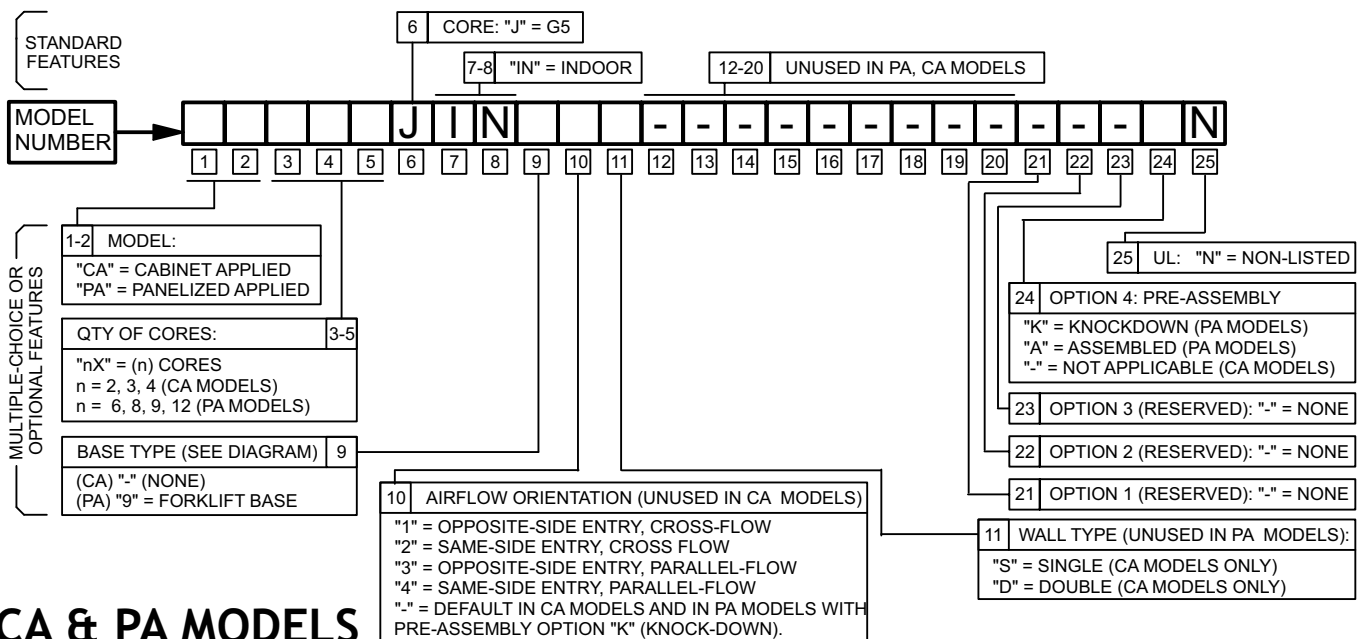

### CA & PA MODELS

# MODEL NUMBERING GUIDE

Note: Not all options are available on every model.

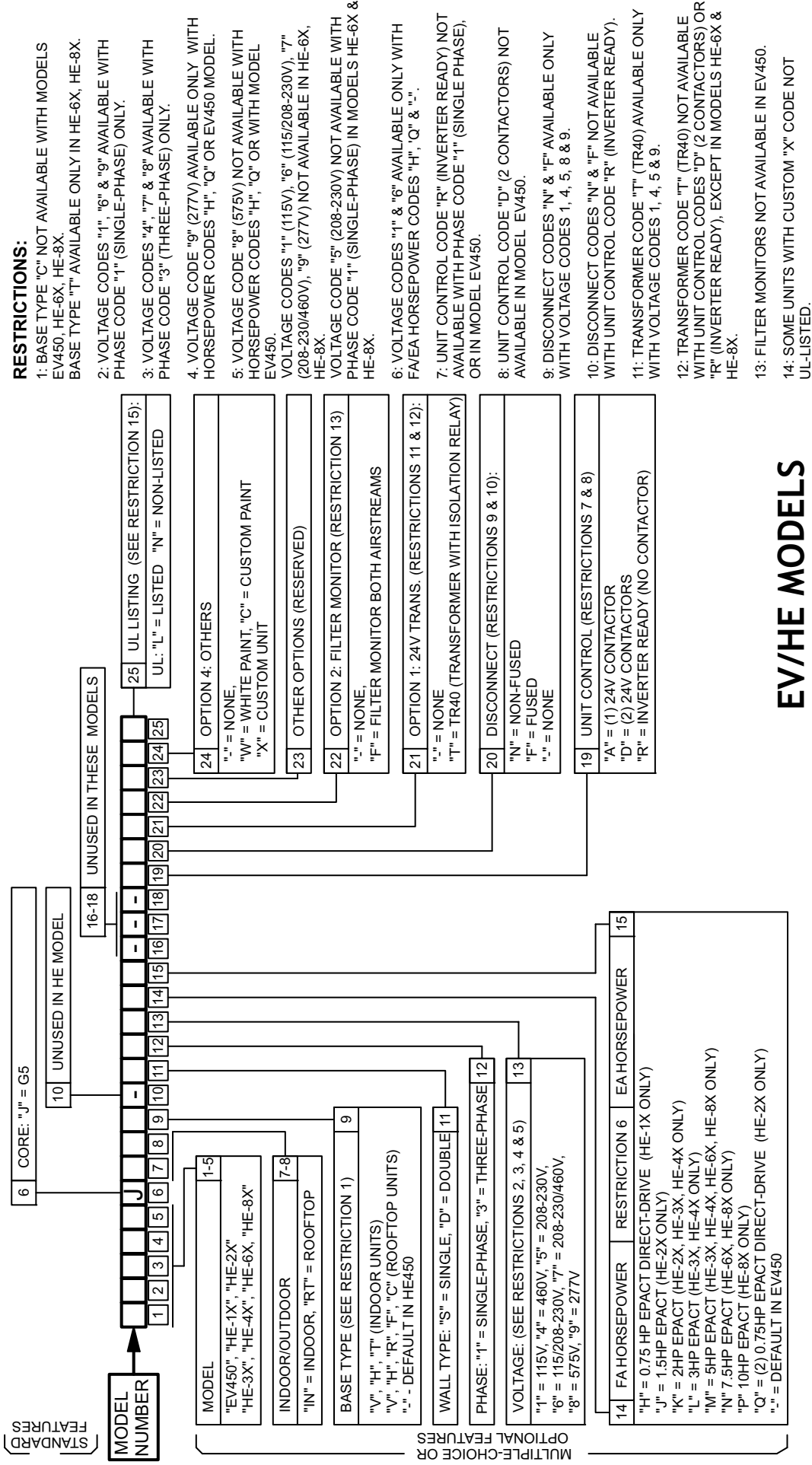

## EV/HE MODELS

For Technical Support E-mail: [Support@RenewAire.com](mailto:Support@RenewAire.com)  
 To Place an Order E-mail: [RenewAireOrders@RenewAire.com](mailto:RenewAireOrders@RenewAire.com)

# RENEWAIRE PRODUCT & VENTILATION COMMITMENT

*RenewAire ventilation products will give you cleaner air to breathe - letting you and your family feel better and healthier AND will do so in the most consistent, controlled, safe and energy-efficient manner possible.*



*For over 30 years, RenewAire has been a pioneer in the use of plate exchangers that simultaneously transfer heat and humidity between ventilation airstreams in extreme climates. From cool-dry (Point Barrow, Alaska) to hot-humid (Puerto Rico) climates, RenewAire exceeds customer expectations for effective, reliable ventilation solutions.*

**1980** First HRV and ERV installations using a variety of plate and wheel technologies.



ERV manufacturing begins using Mitsubishi "Lossnay" core.

**1983**

**1987** RenewAire model is the first listed by UL-1812 standard for ERV safety.

HVI residential unit certification confirms superior heat and humidity transfer.

**1996**

**1998** Introduction of first roof-top connected unit (RTC).

ARI-1060 commercial product certification of only ERV with 0% cross contamination.

**2001**

**2003** Over 100 school projects shipped in one year.



G4 - 4th generation core introduced with enhanced humidity transfer.

**2004**

**2005** Introduction of *BREEZE*® easy to install residential unit.

Energy Star Qualified with energy use in the lowest 20% of comparable buildings.

**2006**

**2007** New factory achieves LEED-Silver rating. 120,000<sup>th</sup> North American unit sold. 2007 sales result in 30,000 tons of CO<sub>2</sub> emission reductions!



Introduction of RD Series dedicated outdoor air system.

**2008**

**2009** Introduction of V-Series Ventilation Exhaust Fans.



G5 - 5th generation core introduced with enhanced humidity transfer.

**2010**

# FULL LINE OF VENTILATION PRODUCTS

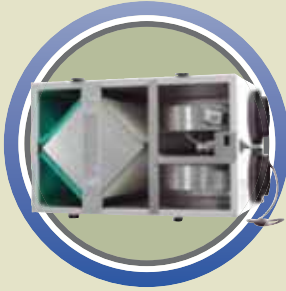

## Residential & Small Commercial

- 5 Models
- 50 - 300 CFM
- built-in 24 V transformer/relay package

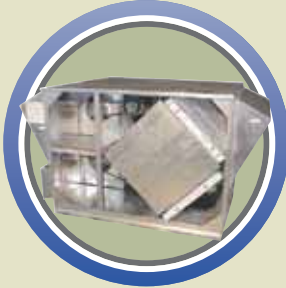

## Commercial Products

- 23 Models
- 250 - 7,950 CFM
- 1 or 3 phase multi-voltage
- 24 volt control

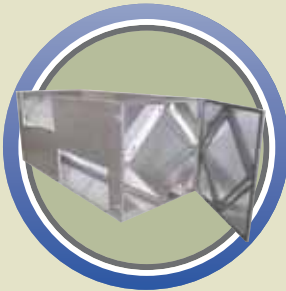

## Applied Products

- CA-Series (cabinet) - 500 - 20,000 CFM
- PA-Series (panelized) - 1,500 - Unlimited CFM
- *(requires blowers & manifolds by others)*

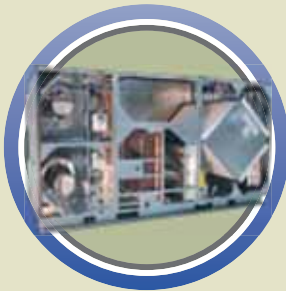

## Dedicated Outdoor Air Systems

- 4 Models
- 500 - 4400 CFM
- integrated VFD for each airstream
- coil options including DX, chilled water, hot water and combinations

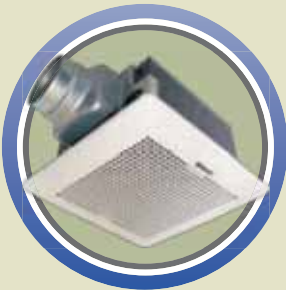

## Ventilation Exhaust Fans

- 4 Models
- 50 - 150 CFM
- robust steel housing and duct collar
- the most efficient line of exhaust fans available in North America

*This piece was printed using earth-friendly soy ink on 100% post-consumer recycled paper.  
RenewAire ERVs are proudly manufactured in our LEED-Silver Certified facility using 100% wind generated electricity.*